



DAKE HYDRAULIC NOTCHER

Model: DLN-6200

INSTRUCTIONAL MANUAL



WARNING!

Read and understand all instructions and responsibilities before operating. Failure to follow safety instructions and labels could result in serious injury.

Dake Corporation
1809 Industrial Park Dr
Grand Haven, MI 49417

Phone: 800.937.3253
Fax: 800.846.3253

www.dakecorp.com

TABLE OF CONTENTS

DAKE STANDARD LIMITED WARRANTY	2
RETURN & REFUND POLICY	4
DAKE STANDARD TERMS & CONDITIONS OF SALE	5
SPECIFICATIONS.....	6
SAFETY.....	6
SAFETY LABELS.....	7
TRANSPORT	10
INSTALLATION	10
GROUNDING INSTRUCTIONS	11
ADJUSTING BLADE GAP	12
ADJUSTING MOBILE SQUARE.....	12
MAXIMUM CUTTING THICKNESS.....	13
CLEANING	13
MAINTENANCE	13
WIRING DIAGRAM	14
HYDRAULIC DIAGRAM	15
EXPLODED VIEW.....	16
PARTS LIST.....	17
ORDERING INFORMATION	18

DAKE STANDARD LIMITED WARRANTY

Finished Machines

Dake warrants to the original purchaser the finished machine manufactured or distributed by it to be free from defects in material and workmanship under normal use and service within 1 year (12 months) from the delivery date to the end user.

Parts

Dake warrants to the original purchaser the component part manufactured or distributed by it to be free from defects in material and workmanship under normal use and service within 30 days from the delivery date to the end user. The standard limited warranty includes the replacement of the defective component part at no cost to the end user.

Sale of Service (Repairs)

Dake warrants to the original purchaser the component part repaired by Dake Corporation at the manufacturing facility to be free from defects in material and workmanship under normal use and service within 90 days from the return date to the end user, as it pertains to the repair work completed. The standard limited warranty includes repair of the defective component part, at no cost to the end user.

Warranty Process

Subject to the conditions hereinafter set forth, the manufacturer will repair or replace any portion of the product that proves defective in materials or workmanship. The manufacturer retains the sole right and option, after inspection, to determine whether to repair or replace defective equipment, parts or components. The manufacturer will assume ownership of any defective parts replaced under this warranty.

All requested warranty claims must be communicated to the distributor or representative responsible for the sale. Once communication has been initiated, the Warranty Representative at Dake Customer Service must be contacted for approval:

Phone: (800) 937-3253

Email: customerservice@dakecorp.com

When contacting Dake, please have the following information readily available: - Model # - Serial # - Sales Order #

Purchasers who notify Dake within the warranty period will be issued a Case number and/or a Return Material Authorization (RMA) number. If the item is to be returned per Dake's request, the RMA number must be clearly written on the exterior packaging. Any item shipped to Dake without an RMA will not be processed.

Warranty Exceptions:

The following conditions are not applicable to the standard limited warranty:

- a) Part installation or machine service was not completed by a certified professional, and is not in accordance with applicable local codes, ordinances and good trade practices.
- b) Defects or malfunctions resulting from improper installation or failure to operate or maintain the unit in accordance with the printed instructions provided.
- c) Defects or malfunctions resulting from abuse, accident, neglect or damage outside of prepaid freight terms.
- d) Normal maintenance service or preventative maintenance, and the parts used in connection with such service.
- e) Units and parts which have been altered or repaired, other than by the manufacturer specifically authorized by the manufacturer.
- f) Alterations made to the machine that were not previously approved by the manufacturer, or that are used for purposes other than the original design of the machine.

RETURN & REFUND POLICY

Thank you for purchasing from Dake! If you are not entirely satisfied with your purchase, we are here to help.

Returns

All Dake manufactured / distributed machines and parts include a 30-day return option. These policies are valid from the date of final shipment to the end user.

To be eligible for a return, the item must be unused and in the same condition as received.

All requested warranty claims must be communicated to the distributor or representative responsible for the sale. Once communication has been initiated, Dake Customer Service must be contacted for approval by the distributor or representative: Phone: (800) 937-3253 Email: customerservice@dakecorp.com

Once the return request has been approved by Customer Service, a representative will supply a Return Material Authorization (RMA) number. The returned item must have the provided RMA number clearly marked on the outside packaging. Any item received without an RMA number clearly visible on the packaging will not be processed. An RMA number can only be provided by the Dake Customer Service team and must be obtained prior to the return shipment.

The item must be shipped and received back to Dake within 30 days from being issued the RMA number, or the return will be void and nonreturnable.

Refunds

Once the item has been received and inspected for damages, a representative will notify the requestor referencing the provided RMA number.

If the return is approved, a refund will be issued to the original method of payment, less a 20% restocking fee. The restocking fee may be waived if an order is placed at the time of return with like-value merchandise.

Transportation costs are the responsibility of the end user and will not be credited upon return approval. Any item that is returned after the initial 30 days or has excessive/obvious use will not be considered for a full refund.

DAKE STANDARD TERMS & CONDITIONS OF SALE

All proposals and quotations for the original sale of our products are subject to the following terms and conditions:

ACCEPTANCE OF ORDER: All orders are subject to acceptance by Dake at its main office in Grand Haven, Michigan.

APPLICABLE LAWS: This quotation or acceptance shall be governed in all respects by the laws of the State of Michigan.

CANCELLATION: We reserve the right to cancel and/or refuse to complete your order if, in our opinion, you have not established credit to promptly meet the payment terms of your order. Any cancellation from the Purchaser may be subject to a 10% cancellation fee for any of our non-standard machinery upon the discretion of Dake. All custom or special quotes will not be eligible for cancellation, nor returns.

DELIVERY: The proposed shipment date is an estimate and is contingent upon causes beyond Dake's control. Under no circumstances shall Dake have any liability for loss of use or for any direct or consequential damages resulting from delay. All shipments from the Dake facilities are F.O.B.

FREIGHT CLAIM: Damage freight claims must be submitted to Dake within thirty (30) days of shipment from Dake's facility. If shipment for order was set up by the Purchaser, Dake is not liable to handle the freight claims.

PERMITS AND COMPLIANCE: Dake shall not be responsible for obtaining any permits, inspections, certifications, or licenses required for the installation or use of the equipment. Dake makes no promise or representation that the equipment or any services to be furnished by Dake will conform to any federal, state, or local laws, ordinances, regulations, codes or standards.

PRICES: Unless otherwise agreed to in writing, all prices are F.O.B. our plant in Grand Haven, Michigan and Grand Prairie, Texas. In any event, the quoted prices for component parts become invalid ten (10) days after date of quotation, and machinery may become invalid sixty (60) days after date of quotation. Unless otherwise specified in Dake's quotation, installation services and final on-site adjustments are not included in the quotation.

TAXES: Prices do not include taxes. If any sales, use or similar tax is payable to Dake in connection with any transaction or part thereof between the Purchaser and Dake with respect to goods delivered, the Purchaser will, upon demand, pay to Dake the amount of any such tax. If you are tax exempt, please include your exemption document when submitting your order.

TERMS OF PAYMENT: Terms of payment are as stated in Dake's quotation subject to credit approval by our home office. Dake will invoice Purchaser when the equipment is completed and ready for shipment. Payment terms run from invoice date. Purchaser may be required to issue a down payment before production of order and shipment, at the discretion of Dake Accounting. For credit card purchases, a 3.5% processing fee may be applicable to the order. The following states are exempt from the 3.5% processing fee: CA, CO, KS, OK, TX, FL, NY, CT, MA, and ME. Dake's preferred method of payment is as follows: ACH Wire and credit card. Checks will be accepted but may cause delay in order processing. Below is our billing address:

1809 Industrial Park Drive, Grand Haven, MI 49417

WARRANTY If, within a period of one (1) year from date of shipment, any part of any equipment sold by Dake is defective in material or workmanship and is so found after inspection by Dake, it will be replaced or repaired at the option of Dake, providing the equipment has been given normal and proper usage and is still the property of the original Purchaser. Purchased components such as Micro Drop mist system or the like, installed as a part of Dake equipment are warranted only to the extent of the original Manufacturer's warranty. Dake is not responsible for any service work performed unless authorized in advance.

THE FOREGOING WARRANTY IS EXCLUSIVE AND IN LIEU OF ALL OTHER WARRANTIES WHETHER WRITTEN, ORAL OR IMPLIED (INCLUDING ANY WARRANTY OF MERCHANTABILITY OR FITNESS FOR PARTICULAR PURPOSE). UNDER NO CIRCUMSTANCES SHALL DAKE BE LIABLE FOR ANY INCIDENTAL OR CONSEQUENTIAL DAMAGES.

SPECIFICATIONS

Motor	4 HP
Blade Length	8.6" x 8.6"
Max Cutting Thickness	6mm
Strokes per minute	15

Table Dimensions	25-1/2" x 25-1/2"
Overall Dimensions	31-1/2 x 25-1/2" x 46.8"
Net Weight	1092lbs.
Noise @ 1 meter	70.2 dB

SAFETY

1. The operator must carefully follow recommendations provided and instructions herein stated for a better use, and preservation of the machine to avoid any damage to people or things.
2. When you unpack the machine, follow instructions provided by us in the relevant chapter carefully.
3. Before starting the machine, make sure there are no dangerous conditions for personnel in charge of the operation and no unauthorized object has been left inside or above the machine.
4. Keep the bench and/or work area clean and tidy to avoid any hindrance on portions of already cut material.
5. Verify that fixed hand protections are properly installed.
6. The use of gloves is highly recommended to avoid injuries.
7. It is advisable to take off clothes such as scarves, ties etc... along with jewelry and trinkets such as rings, watches, bracelets etc....
8. It is forbidden to cut material having a higher thickness or features differing from those for which the machine has been designed.
9. For cleaning, please read instructions for maintenance carefully.
10. In case of emergency, press the red button (Emergency Stop).
11. Before carrying out any maintenance operation, be sure that the main switch of the machine, placed on the control box is disconnected and locked to avoid accidental starting.
12. Carrying out controls, checking maintenance operations, take special care of all protruding parts to avoid any possible injuries.
13. Oil is not furnished with the machine, so fill it in at installation.
14. Do not throw the hydraulic oil, follow your local regulations on disposing of hydraulic oil.
15. The operator must be aware that the emergency stop button is designed to immediately set the machine's process to a halt when it is activated. Hence, preventing any electrical and mechanical parts to further move or cause any damage. Therefore it can be used to stop the machine immediately at any instance to ensure the safety of the user and/ or the machine. However, the machine's power won't be cut-off when the emergency button is activated. Hence to recover from emergency stop state, simply twist the emergency stop button clockwise.

SAFETY LABELS



Figure 1. Warning label on safety cover.

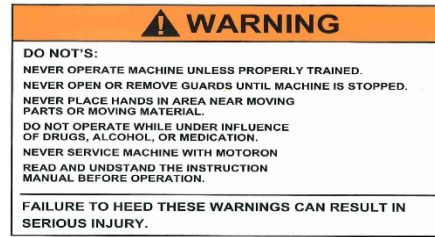

Figure 2. General safety rules to operate this machine



Figure 3. Disconnect Power label

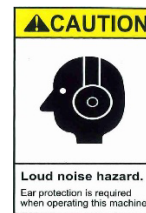

Figure 4. Operator needs to wear ear protection while operating this machine

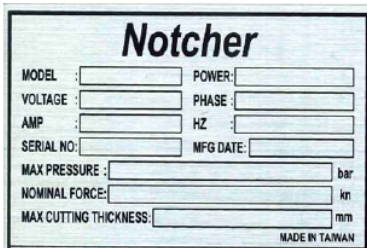

Figure 5. Specification plate



Figure 6. Emergency Stop



Figure 7. Shows main electrical power supply wire location. Connect machine with same voltage power as the motor.



Figure 8. Electrical Hazard Label

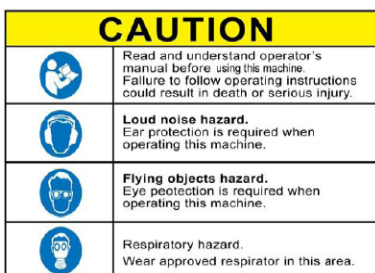

Figure 9. Multi Safety Label

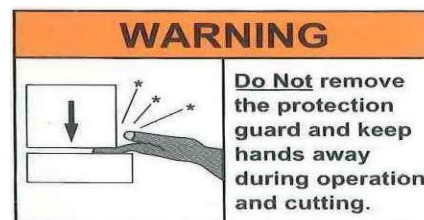

Figure 10. Guarding label – do not remove guarding & keep hands away from point of operation



Figure 11. Hook installation point

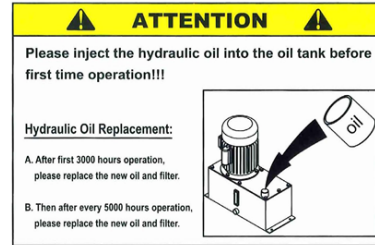

Figure 12. Fill with oil before use.

Notcher

MODEL	POWER
VOLTAGE	PHASE
AMP	HZ
SERIAL NO.	MFD DATE
MAX PRESSURE	bar
NOMINAL FORCE	kg
MAX CUTTING THICKNESS	mm

MADE IN CANADA

WARNING

DO NOT remove the safety cover under operation. Failure to follow warning may result in serious injury.

CAUTION

HOOK INSTALLATION POINT

CAUTION

Before make any service or maintenance, please make sure air or electric power supply is disconnected. Failure to follow caution may result in serious injury.

CAUTION

	Read and understand operator's manual before using the machine. Failure to follow operating instructions could result in death or serious injury.
	Loud noise hazard. Ear protection is required when operating this machine.
	Flying objects hazard. Eye protection is required when operating this machine.
	Respiratory hazard. Wear approved respirator in this area.

EMERGENCY STOP

Trouble Shooting

If the head set can not move up and down, please switch the wiring L1 & L2 of the power cord. (For 3 phase motor only)

CT-M001

CAUTION

Loud noise hazard. Ear protection is required when operating this machine.

WARNING

DO NOT:
NEVER OPERATE MACHINE UNLESS PROPERLY TRAINED.
NEVER OPERATE OR REMOVE GUARDS UNTIL MACHINE IS STOPPED.
NEVER PLACE HANDS IN AREA NEAR MOVING PARTS OR MOVING MATERIAL.
DO NOT OPERATE WITH EYE UNDER INFLUENCE OF DRUGS, ALCOHOL, OR MEDICATION.
NEVER SERVICE MACHINE WITH MOTOR ON.
READ AND UNDERSTAND THE INSTRUCTION MANUAL BEFORE OPERATION.
FAILURE TO HEED THESE WARNINGS CAN RESULT IN SERIOUS INJURY.

ATTENTION

Please inject the hydraulic oil into the oil tank before first time operation!!!

Hydraulic Oil Replacement:

- After first 1000 hours operation, please replace the seal of seal disc.
- Then after every 1000 hours operation, please replace the seal of seal disc.

WARNING

Do Not remove the protection guard and keep hands away during operation and cutting.

TRANSPORT

Package handling must be carried out exclusively using a forklift truck with features suitable for hoisting the package taking into account the weight and dimensions of the package.

Position the forks to keep the package properly balanced.

Remove packaging materials and unscrew the machine from the pallet.

Remove the scrap container that is one the machines work table to prevent it from falling during handling.

Machine loading and unloading should only occur using a hoist and lifting from the eyebolt on the top of the machine.

Never handle the machine manually or by any means that would result in injury of the operator and machine damage.

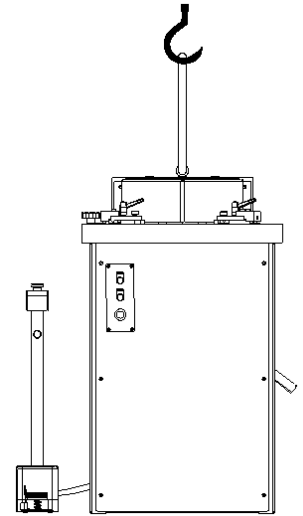

INSTALLATION

1. Using the lifting eye on the top of the machine, lift and place the machine in the work area. Make sure there is enough space for production operation and safety of the operator.
2. Place foot pedal control at best position for the operator.
3. Unscrew the screws holding the front cover close. Then fill oil tank(3) with DTE #24 hydraulic oil or equivalent. Fill until oil reaches 4/5 on the oil indicator(2). 35 liters, about 9 gallons of oil.
4. The pressure gauge(4) is pre-set to 2100 psi. *Do not modify unless done so by a professional.*

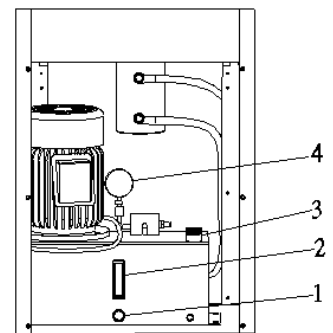

GROUNDING INSTRUCTIONS

The appliance must be grounded, if it should malfunction or breakdown, grounding provides a path of least resistance for electric current to reduce the risk of electric shock. This appliance is equipped with a cord having equipment-ground conductor and grounding plug. The plug must be inserted into an appropriate outlet that is properly installed and grounded in accordance with all local codes and ordinances.

 **WARNING** Improper connection of the equipment-grounding conductor can result in a risk of electric shock. Check with a qualified electrician or service person if you are in doubt as to whether the outlet is properly grounded. Do not modify the plug provided with the appliance – if it will not fit the outlet; have a proper outlet installed by a qualified electrician.

For Grounded, Cord-Connected Machine:

This appliance is for use on a circuit having a normal rating and is factory-equipped with a specific electric cord and plug to permit connection to a proper electric circuit. Make sure that the appliance is connected to an outlet having the same configuration as the plug. No adaptor should be used with this appliance. If the appliance must be reconnected for use on a different type of electric circuit, qualified service personnel should make the reconnection.

For Permanently Connected Machine:

This appliance must be connected to a grounded metal, permanent wiring system; or an equipment-grounding conductor must be run with the circuit conductors and connected to the equipment grounding terminal or lead on the appliance.

OPERATING CONDITIONS:

Voltage Steady state voltage: 0,9 to 1,1 of nominal voltage.

Frequency 0,99 to 1,01 of nominal frequency continuously; 0,98 to 1,02 short time.

Harmonics Harmonic distortion not exceeding 10% of the total r.m.s. voltage between live conductors for the sum of the 2nd through to the 5th harmonic.

Voltage interruption Supply interrupted or at zero voltage for not more than 3 ms at any random time in the supply cycle with more than 1 s between successive interruption.

Voltage dips Voltage dips not exceeding 20% of the peak voltage of the supply for more than one cycle with more than 1 s between successive dips.

The minimum requirement for all electrical equipment is correct operation between air temperature of +5°C and +45°C.

Electrical equipment is capable of operating correctly when the relative humidity does not exceeding 50% at a maximum temperature of +45°C.

Electrical equipment is capable of operating correctly at altitude up to 1000 m.

Electrical equipment is designed to withstand to protected against the effects of transportation, and storage temperature within a range of -25°C to +55°C and for short periods not exceeding 24h at up to +70°C.

Avoid exposing to vibration environment. Avoid exposing to direct sunlight or heat rays.

Have to connect to the factory grounding system correctly away from electric magnetic interference source sites, such welding, and discharge machine.

ADJUSTING BLADE GAP

1. Disconnect machine from it's power source.
2. Unscrew the screws(2) and remove the safety cover.
3. Loosen the bias screws(4) and blade screws(5) to measure the blade gap.
4. Using the .25mm thickness gauge provided, adjust the upper and lower blades against the thickness gauge and tighten screws(4 & 5) so that the blade gap is at .25mm.

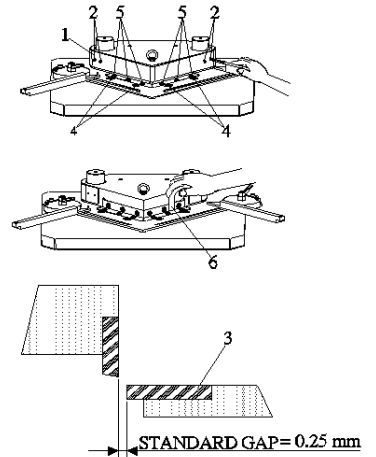

ADJUSTING MOBILE SQUARE

1. Loosen handle (5) to the length for the workpiece.
2. Take out pin (6) and adjust to what angle is needed.
3. Adjust left and right block (8) to match work piece.

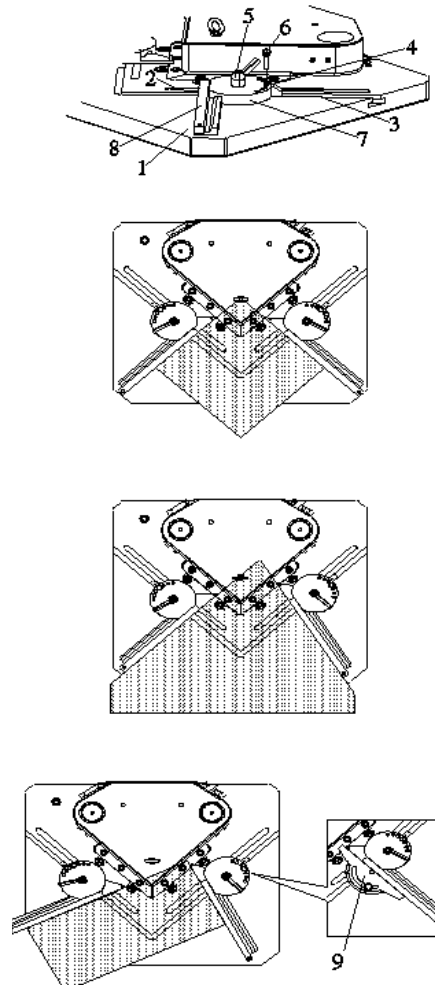

MAXIMUM CUTTING THICKNESS

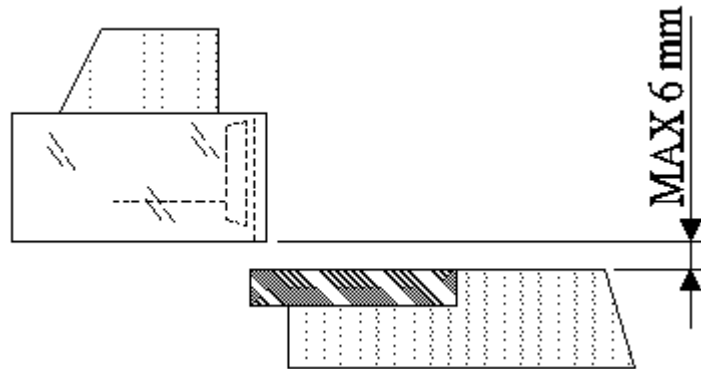

CLEANING

Keep the working table clean to avoid material fragments may damage the machine operation or operator.

DO NOT USE A WATER JET TO CLEAN

MAINTENANCE

⚠ Do not perform any maintenance on the machine until the machine has been properly locked out and disconnected from it's power supply

Hydraulic oil and filter needs replacing after the first 3,000 hours of operation, and then every 5,000 hours after the first replacement.

WIRING DIAGRAM

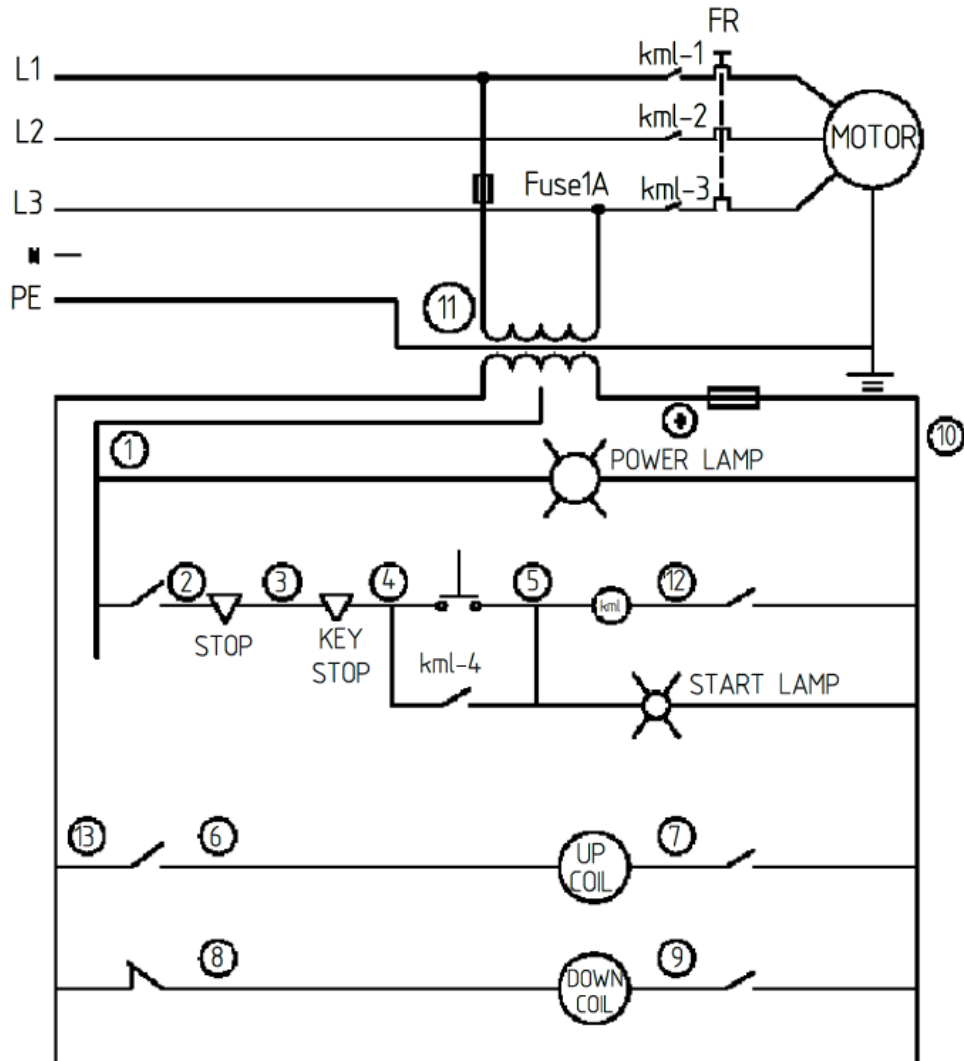

HYDRAULIC DIAGRAM

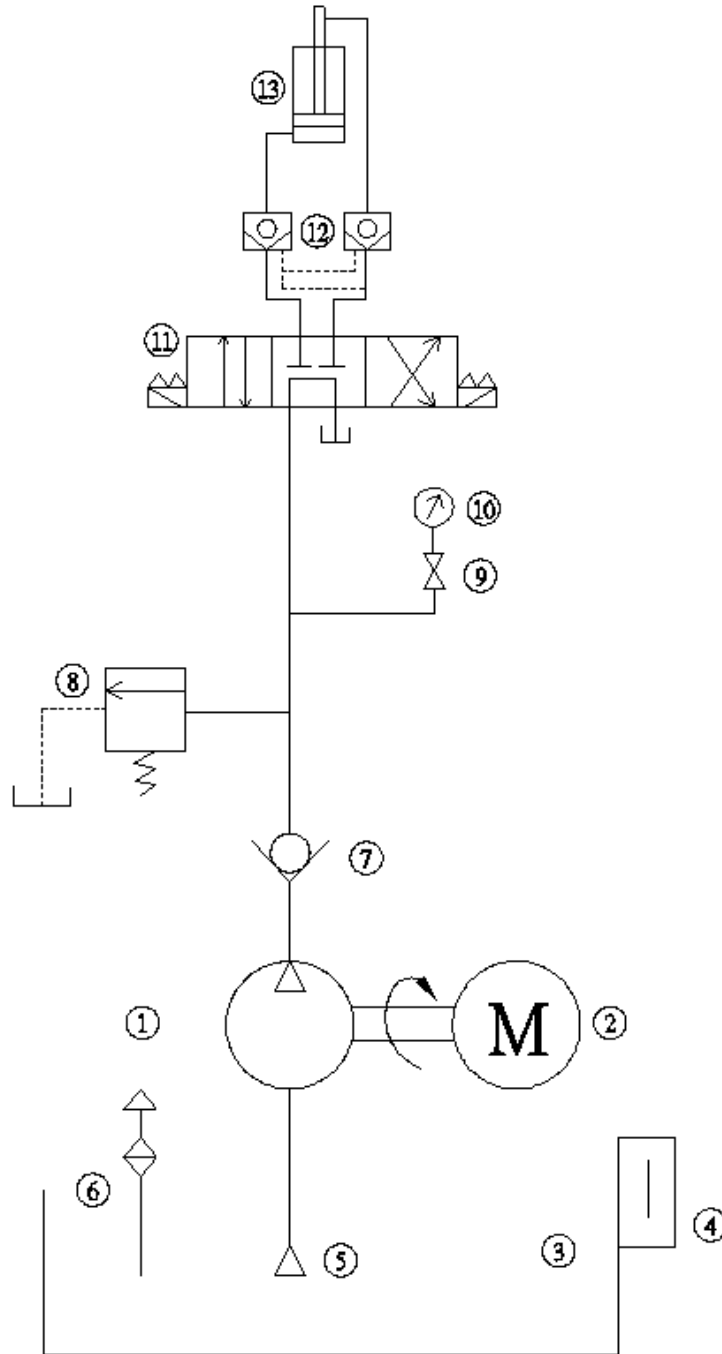

REF.	DESCRIPTION
1	4 HP Motor
2	Hydraulic Pump
3	Oil Tank
4	3" Oil Gauge
5	Oil Filling Point
6	1/2" Filter

REF.	DESCRIPTION
7	3/8" Solenoid Valve
8	1/4" Pressure Gauge Cut Off
9	250 KGS Oil Gauge
10	Pressure Regulator
11	Terminal Block
12	Hydraulic Cylinder Unit

EXPLODED VIEW

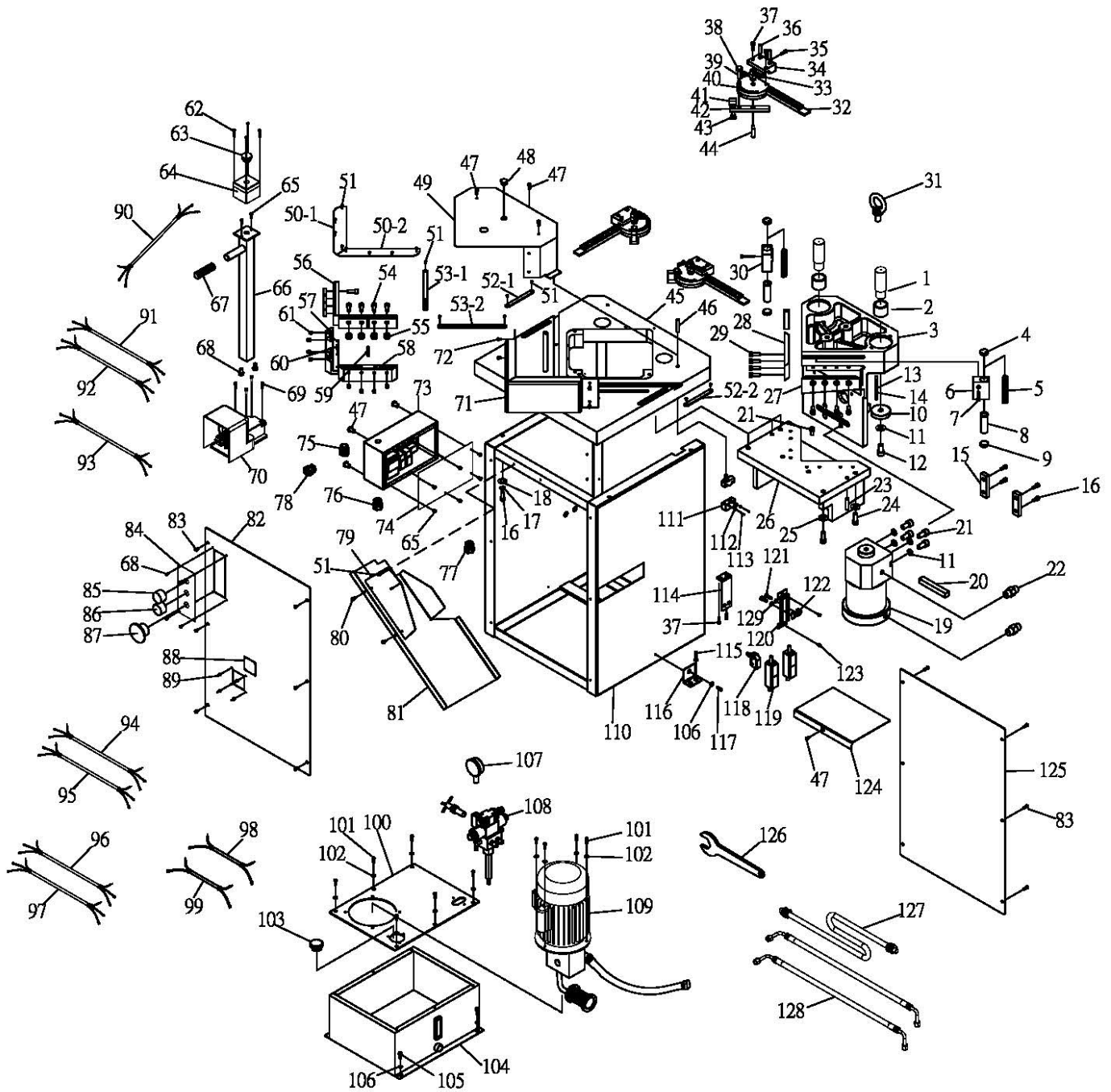

PARTS LIST

<u>Item</u>	<u>Description</u>	<u>Part No.</u>	<u>Qty</u>
1	Spindle		2
2	Copper Rod		2
3	Head Set		1
4	Cap		2
5	Spring		2
6	Fixed Block (Right)		1
7	Cap Screw (M6x45mm)		2
8	Fixing Rod		2
9	Pad		2
10	Spindle Packing		2
11	Spring Washer (M16)		6
12	Cap Screw (M16x30mm)		2
13	Block		2
14	Flat Head Screw (M4x25mm)		4
15	Packing		2
16	Cap Screw (M8x20mm)		8
17	Spring Washer (M8)		4
18	Washer (5/16"x 23mmx2mm)		4
19	Cylinder		1
20	Cylinder Key (20x20x150mm)		1
21	Cap Screw (M16x40mm)		5
22	Oil Bushing		4
23	Fixed Pin		2
24	Cap Screw (M12x50mm)		6
25	Spring Washer (M12)		6
26	Lower Set		1
27	Upper Cutter (Right)	304167	1
28	Upper Cutter (Left)	304168	1
29	Cap Screw (M10x20mm)		8
30	Fixing Block (Left)		1
31	Hook		1
32	Angle Block		2
33	Handle		2
34	Angle Fixing Plate		2
35	Cap Screw (M6x20mm)		2
36	Set Screw (M12x25mm)		4
37	Cap Screw (M8x25mm)		6
38	Knob		2
39	Adjusting Pin		2

<u>Item</u>	<u>Description</u>	<u>Part No.</u>	<u>Qty</u>
52-1	Short Indicator (Left)		1
52-2	Short Indicator (Right)		1
53-1	Long Indicator (Left)		1
53-2	Long Indicator (Right)		1
54	Cap Screw (M10x30mm)		8
55	PU Rod		8
56	Cutter	304171	2
57	Cutter Set (Left)	304172	1
58	Cutter Set (Right)	304173	1
59	Key (6x6x40mm)		2
60	Fixing Pin (Ø6x20mm)		6
61	Square Set Screw (M10x12mm)		8
62	Cross Head Screw (M4x45mm)		4
63	Emergency Stop Switch		1
64	Emergency Stop Switch Box		1
65	Cross Head Screw (M4x8mm)		8
66	Emergency Stop Switch Rod		1
67	Handle Cap		1
68	Cross Head Screw (M6x12mm)		6
69	Cross Head Screw (M5x15mm)		4
70	Footpad Control Switch		1
71	Safety Cover		1
72	Button Head Screw (M6x8mm)		4
73	Control Box		1
74	Control Box Cover		1
75	Bushing		1
76	Bushing		5
77	Bushing		2
78	Wire Tube		1
79	Side Cover Board		1
80	Cross Head Screw (M5x8mm)		2
81	Scrap Discharge Chute		1
82	Front Cover		1
83	Button Head Screw (M8x16mm)		12
84	Switch Fixing Plate		1
85	Start Bottom		1
86	Power Light		1
87	Emergency Stop Switch		1
88	PC Board		1

<u>Item</u>	<u>Description</u>	<u>Part No.</u>	<u>Qty</u>
40	Angle Block		2
41	Fixing Block		2
42	Block		2
43	Cap Screw (M5x12mm)		4
44	Pin		2
45	Table		1
46	Stop Pin		1
47	Button Head Screw (M6x12mm)		8
48	Cap		1
49	Head Set Cover		1
50-1	Cutter Set Cover (Left)	304169	1
50-2	Cutter Set Cover (Right)	304170	1
51	Flat Head Screw (M4x8mm)		18
102	Washer (Ø8x18x2mm)		10
103	Oil Tank Cap		1
104	Oil Tank		1
105	Cap Screw (M8x16mm)		4
106	Washer (5/16x18mm)		8
107	Oil Pressure Indicator		1
108	Electric Distributor		1
109	Motor		1
110	Base		1
111	Switch Cover		3
112	Nut (M4)		6
113	Cross Head Screw (M4x30mm)		6
114	Limit Switch Board		1
115	Screw		2

<u>Item</u>	<u>Description</u>	<u>Part No.</u>	<u>Qty</u>
89	Rivet		4
90	Emergency Switch Cord		1
91	Footpad Switch Cord		1
92	Limit Switch Stop Cord		1
93	Limit Switch Cord		1
94	Power Cord		1
95	Motor Cord		1
96	Switch Cord (Upper)		1
97	Switch Cord (Lower)		1
98	Connect Cord		1
99	Connect Cord		1
100	Oil Tank Cover		1
101	Hex. Head Screw (M8x20mm)		10
116	Fixing Plate		2
117	Hex. Head Screw (M8x12mm)		2
118	Limit Switch		1
119	Limit Switch		2
120	Limit Switch Plate		1
121	Hex. Head Screw (M5x10mm)		2
122	Set Block		2
123	Button Head Screw (M5x10mm)		2
124	Lead Plate		1
125	Rear Cover		1
126	Open Wrench (M8)		1
127	Wire Tube		1
128	Oil Tube		2
129	Washer (M5x10mm)		10

Please contact factory for current prices.

ORDERING INFORMATION

Parts are available for direct purchase from Dake or through a distributor. When placing a parts order, you will need to provide the part number, name of part, and model number. All parts shipped F.O.B. Factory in Grand Haven, MI.