

GEAR BOX COMPONENT

0500	1 *	GEAR BOX
0510	1 *	GEAR BOX COVER 303243
0520	1 *	GEAR
0521	1 *	GEAR
0530	1 *	SCREW NUT
0531	1 *	SCREW NUT
0540	1 *	GEAR 303245
0550	1 *	GEAR SHAFT
0560	1 *	SHAFT COVER
0570	1 *	GEAR 303244
0580	1 *	MAIN SHAFT
0591	1 *	MAIN SHAFT COVER
0600	1 *	SPEED CHANGING SHAFT
0610	1 *	SPEED CHANGING ARM
0611	1 *	SHAFT STOPPER
0612	1 *	SPRING
0620	1 *	SLIDE BLOCK
0630	1 *	CLUTCH
0631	2 *	BRASS BRACKET
0632	1 *	BRASS BRACKET
G6008	1 *	BALL BEARING
G6206	1 *	BALL BEARING
G6303	1 *	BALL BEARING
G6304	1 *	BALL BEARING
L4030	1 *	OIL SEAL
L5230	1 *	OIL SEAL
L5840	1 *	OIL SEAL
CP0500	1	GEAR BOX COMPLETE 303242
0700	1	SPEED CHANGING LEVER
0740	1	SHAFT HOUSING
0790	1	SPEED LEVER RIGHT
7071	1	PULLEY 303228
9220	1	LEVER KNOB
BA44	2	V-BELT, 7071+7300 (60HZ)
BA45	2	V-BELT, 7071+7300 (50HZ)

WORK TABLE COMPONENT

1011	1	WORK TABLE
1021	1	TABLE SUPPORT FRAME
1080	2	BLADE GUARD

GUIDE POST COMPONENT

1311	1	GUIDE SUPPORT, UPPER
1312	1	GUIDE SUPPORT, LOWER
1320	4	BLADE GUIDE 303233
1331	1	BLADE STOPPER, LONG 303251
1332	1	BLADE STOPPER, SHORT 303263
1333	1	ECCENTRIC SHAFT
1350	1	BLADE GUIDE POST
1351	1	GEAR BAR
1360	1	GUIDE POST HOUSING
1370	1	BLADE GUARD, LEFT
1380	1	BLADE GUARD, RIGHT
1400	2	SPRING
1410	1	SPRING HOUSING
1440	1	POST HOUSING SPRING
1450	1	POST ELEVATING GEAR
1650	1	CIRCLE CUTTING ATTACHMENT
9015	1	GUIDE POST LOCK
9033	1	POST ELEVATE HANDWHEEL
9230	1	HANDLE KNOB
G6201	1	BALL BEARING

MAIN DRIVE

2000	1	MAIN DRIVE MOTOR 303255
2011	1	MOTOR PULLEY
2020	4	MOTOR ROTARY SEAT
BA43	2	V-BELT, 2011+7070
BA60	1	V-BELT, 2011+4450

WHEEL COMPONENT

3010	1 *	LOWER WHEEL
3020	1 *	RUBBER TIRE 303261
CP3010	1	LOWER WHEEL COMPLETE
3030	1	TAPER SLEEVE
3040	1	WHEEL LOCKING NUT
3020	1 *	RUBBER TIRE
3050	1 *	UPPER WHEEL
G6305	2 *	BALL BEARING
CP3050	1	UPPER WHEEL COMPLETE
3060	1	UPPER WHEEL LOCK

WORK TABLE CONT.			WHEEL COMPONENT CONT.		
			3080	1 *	SLIDE BLOCK HOUSING
1090	1	TABLE SUPPORT HOUSING	3090	1 *	SLIDE BLOCK SEAT
1100	1	GUIDE SUPPORT HOUSING	3100	2 *	SLIDE BLOCK GUIDE
1120	1	RIGHT-HANDED SCREW	3110A	1 *	UPPER WHEEL SLIDER
1140	1	LEFT-HANDED SCREW	3116	1 *	SLIDER SCREW SHAFT
1150	1	SLIDER	3120	1 *	WHEEL ELEVATE SHAFT
1160	1	TABLE TILT ADJUST SCREW	3121	1 *	SPRING
1230	4	BEARING COVER	3150	1 *	WASHER
1250	2	TABLE STROKING SHAFT	3180	3 *	INDICATOR RING
1501	1	MITER GAUGE 304068	CP3080	1	SLIDE HOUSING COMPLETE
1551	1	RIP FENCE + LOCK 303256	3190	1	TENSION INDICATOR
1600	2	T-BLOCK	3200	1	WHEEL TILT ADJUSTER
1610	1	RIP FENCE SLIDE GUIDE	3220	1	WHEEL TILT CONNECTER
2500	1	TORQUE MOTOR	3240	1	CONNECTER WASHER
2501	1	TORQUE MOTOR SPEED REDUCER	3250	1	CONNECTER HOUSING
2510	1	WHEEL GEAR	9030	1	HANDWHEEL
2520	1	SLIDE GEAR	9060	1	TILT ADJUST HANDWHEEL
2530	1	TORQUE MOTOR HOUSING			
2610	1	SET RING SLIDE BAR			
2620	2	LIMITED SWITCH SET RING			
2650	1	LIMITED SWITCH HOUSING			
6165	2	LIMITED SWITCH			
9017	2	SET RING LOCK			
GLM35	4	LINER BEARING			

AIR PUMP COMPONENT

4060	2	AIR PUMP SEAT
4170	1	AIR NOZZLE
4180	1	AIR NOZZLE CLIPPER
4450	1	AIR COMPRESSOR 303229
BA60	1	V-BELT, 2011+4450

MAIN BODY & MISCELLANEOUS

5000	1	MAIN BODY
5100	1	REAR DOOR, LARGER
5101	1	REAR DOOR, SMALLER
5120	1	LOWER DOOR
5140	1	UPPER DOOR
8111	1	CONTROL PLATE

VARIATOR COMPONENT

7000	1	MOTOR SPRING HOUSING
7010	1 *	SPRING
7020	1 *	VAEIATOR DISK, UPPER
7030	1 *	VAEIATOR DISK, UPPER
7040	1 *	VARIATOR HOUSING TUBE
7050	1 *	VARIATOR SHAFT
7060	1 *	VARIATOR HOUSING
G6007	1 *	BALL BEARING
G6205	2 *	BALL BEARING
CP7060	1	VARIATOR HOUSING
7070	1	PULLEY
7080	1	WORM GEAR
7090	1	WORM GEAR HOUSING
7100	1	GEAR SHAFT
7110	1	WORM
7120	1	WHIRLING ARM
7200	1 *	SPRING HOUSING
7210	1 *	SPRING

8372	1	VARIATOR INSTRUCTION	7220	1	*	VARIATOR DISK, LOWER
8422	1	GEAR BOX INSTRUCTION	7230A	1	*	VARIATOR DISK, LOWER
8712	1	INDICATOR PLATE	7260	1	*	SHAFT HOUSING
8743	1	TILT INSTRUCTION	G6007	1	*	BALL BEARING
9300	2	UPPER DOOR HINGE	G6204	1	*	BALL BEARING
9310	6	HINGE	CP7260	1		SHAFT HOUSING COMPLETE
9500	4	SPRING PLATE	7290	1		SPEED CHANGE WHEEL SEAT
9590	2	HANDLE ARM	7300	1		PULLEY
9600	1	CHIP STOPPER	7310	1		SPEED READOUT DETECTOR 303264
9700	1	INDICATE MIDDLE	7330	1		DIGITAL TACHOMETER 303238
9780	1	BRUSHER BRACKET	9030	1		HANDWHEEL
9790	1	CHIP BRUSHER 303237	BA44	-		V-BELT, 7071+7300 (60HZ)
9850	1	KEY FOR REAR DOOR	BA45	-		V-BELT, 7071+7300 (50HZ)
9880	1	CHIP COLLECTOR	BA43	-		V-BELT, 2011+7070
9999	1	EYE BOLT	BV875	1		V-BELT

CONTROL SWITCH COMPONENT

6245	1	VARIABLE TRANSFORMER
6600	2	PUSH BUTTON, ON, GREEN
6601	1	PUSH BUTTON, ON, WHITE
6602	1	PUSH BUTTON, OFF, RED
6603	2	PUSH BUTTON, ON/OFF, BLACK
6610	1	EMERGENCY SWITCH
6620	2	DOOR LIMIT SWITCH 303239
6650	1	KEY SWITCH
6682	1	SELECT SWITCH
6700	1	MAIN POWER SWITCH
6713	1	MAGNETIC SWITCH 303254
6723	1	OVERLOAD STARTER 303258
6730	1	CONDENSER
6741	1	PILOT LAMP, GREEN
6745	1	VOLTAGE REDUCER 303266
6752	4	FUSE SEAT
6753	1	FUSE SEAT
6754	1	FUSE SEAT
6717	3	POWER RELAY
6770	3	WIRE HOUSING
6771	1	GROUND SEAT
6774	1	WIRE HOUSING
6798	1	ELECTRIC BOX
6799	1	WIRING PLATE

CVHN (D)

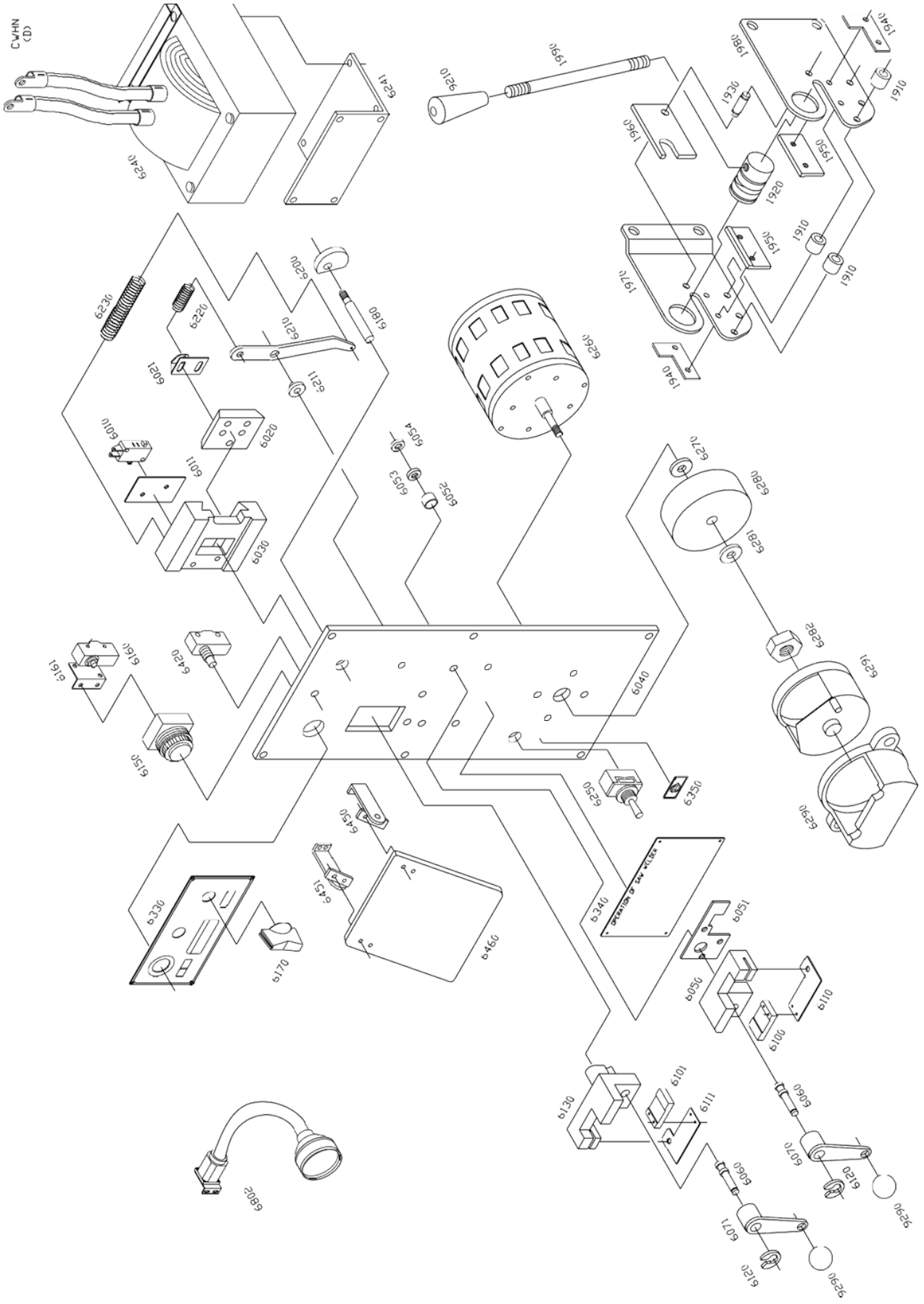

WELDER COMPONENT

6010	1 *	LIMIT SWITCH 303250
6011	1 *	INSULATOR
6020	1 *	GUIDE BLOCK
6040	1 *	HOUSING
6050	1 *	STATIONARY JAW
6051	1 *	INSULATOR
6052	3 *	INSULATING TUBE
6053	3 *	WASHER, INSULATE
6054	3 *	SPACER
6060	2 *	ECCENTRIC SHAFT
6070	1 *	CLAMP LEVER, RIGHT
6071	1 *	CLAMP LEVER, LEFT
6100	1 *	CLAMP SUPPORT, RIGHT
6101	1 *	CLAMP SUPPORT, LEFT
6110	1 *	CLAMP PLATE, RIGHT
6111	1 *	CLAMP PLATE, LEFT
6120	2 *	CAM
6130	1 *	MOVING JAW
6150	1 *	WELD BUTTON 303271
6160	1 *	MICRO SWITCH
6161	1 *	MICRO SWITCH BRACKET
6170	1 *	PRESSURE ADJUST KNOB
6180	1 *	SHAFT
6200	1 *	CAM
6210	1 *	WELD TENSION ARM
6211	1 *	BUSHING
6220	1 *	SPRING, SHORTER
6230	1 *	SPRING, LONGER
6240	1 *	TRANSFORMER (4.2KVA)
6241	1 *	MOUNTING BRACKET (4.2KVA ONLY)
6250	1 *	SWITCH
303787	1 *	GRINDER MOTOR
6270	1 *	SPACER
6280	1 *	GRINDER WHEEL 303248
6281	1 *	1/4" WASHER, FLAT
6282	1 *	6 mm-1.0 HEX NUT
6290	1 *	GRINDER GUARD 303247
6291	1 *	GRINDER COVER 303246
6330	1 *	WELDER NAME PLATE
6340	1 *	INSTRUCTION LABEL
6350	1 *	GRINDER LABEL
6420	1 *	ANNEAL BUTTON 303231
6450	1 *	DEFLECTOR BRACKET, RIGHT
6451	1 *	DEFLECTOR BRACKET, LEFT
6460	1 *	SPARK DEFLECTOR
9290	2 *	KNOB 303249
WCP	1	42-WELDER ASSEMBLY

Electric appliance arrangement
diagram

WORK LAMP COMPONENT

6802	1 *	WORK LAMP COMPONENT 303272 Bulb MR 16 12v 20W
------	-----	--

SHEAR COMPONENT

1910	3 *	SPINDLE BUSHING
1920	1 *	SPINDLE LIFT
1930	1 *	BLADE SHAFT
1940	2 *	VANED IRON PLATE
1950	2 *	LOWER BLADE
1960	1 *	UPPER BLADE
1970	1 *	JOINT PLATE, LEFT
1980	1 *	CHAIN JOINT, RIGHT
1990	1 *	HANDLE BAR
9210	1 *	KNOB
SCP	1	SHEAR COMPLETE 303234

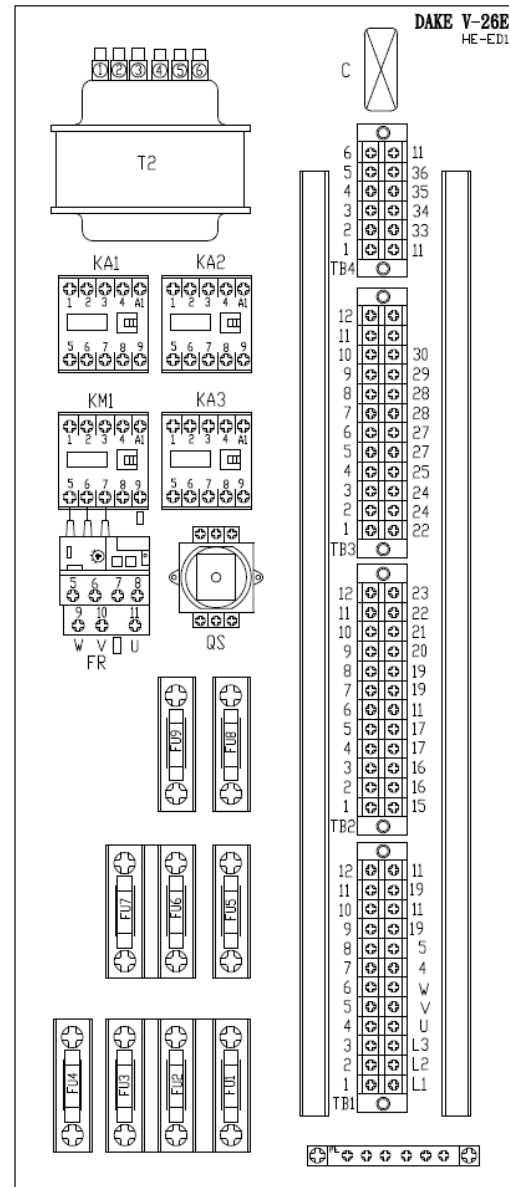

DAKE V-26E

WIRING DIAGRAM

AC 3 ϕ 200V~240V

AC 3 ϕ 380V~460V

AC 3 ϕ 500V~600V

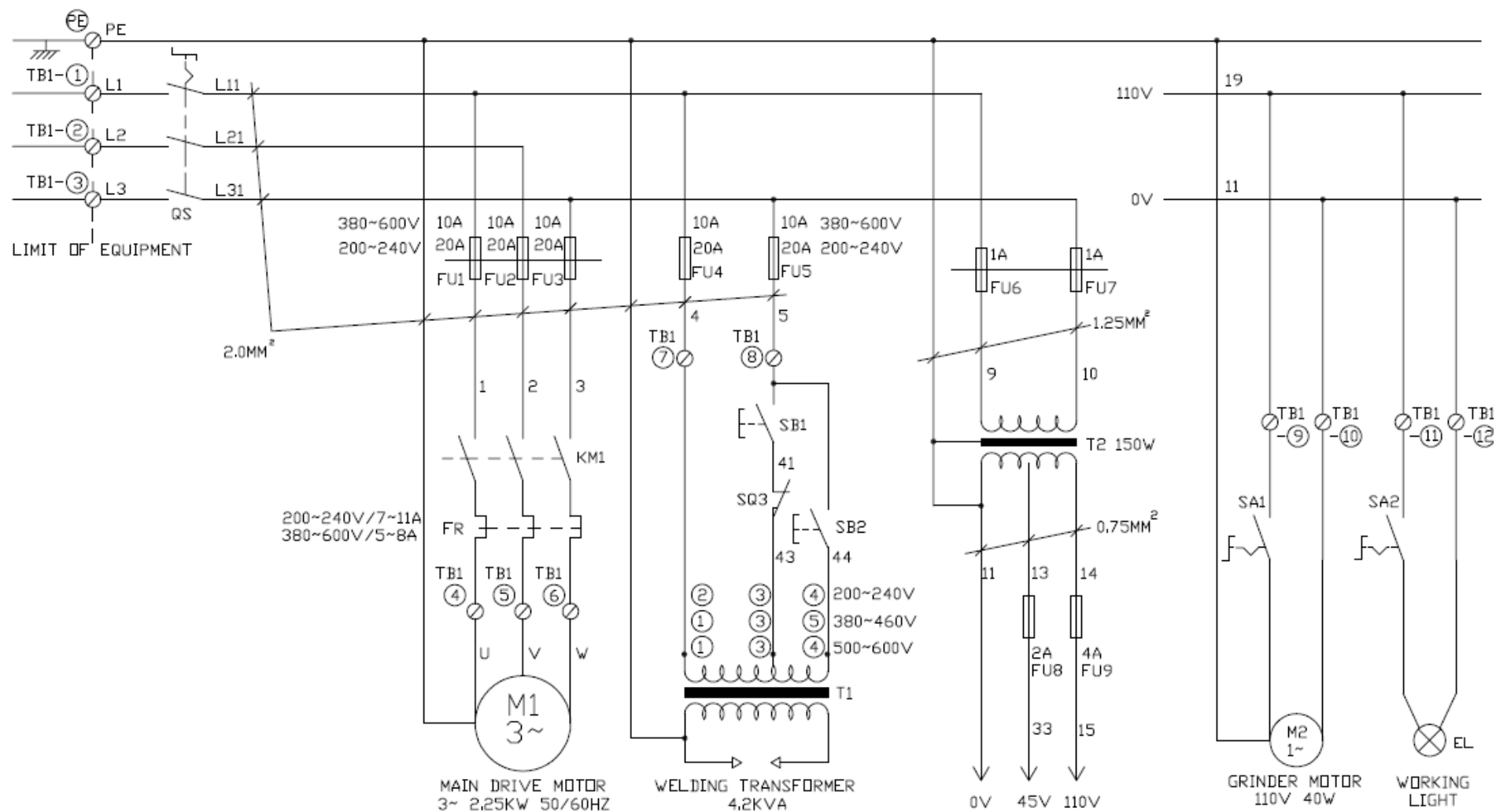

DAKE V-26E

HE-ED1
2/2

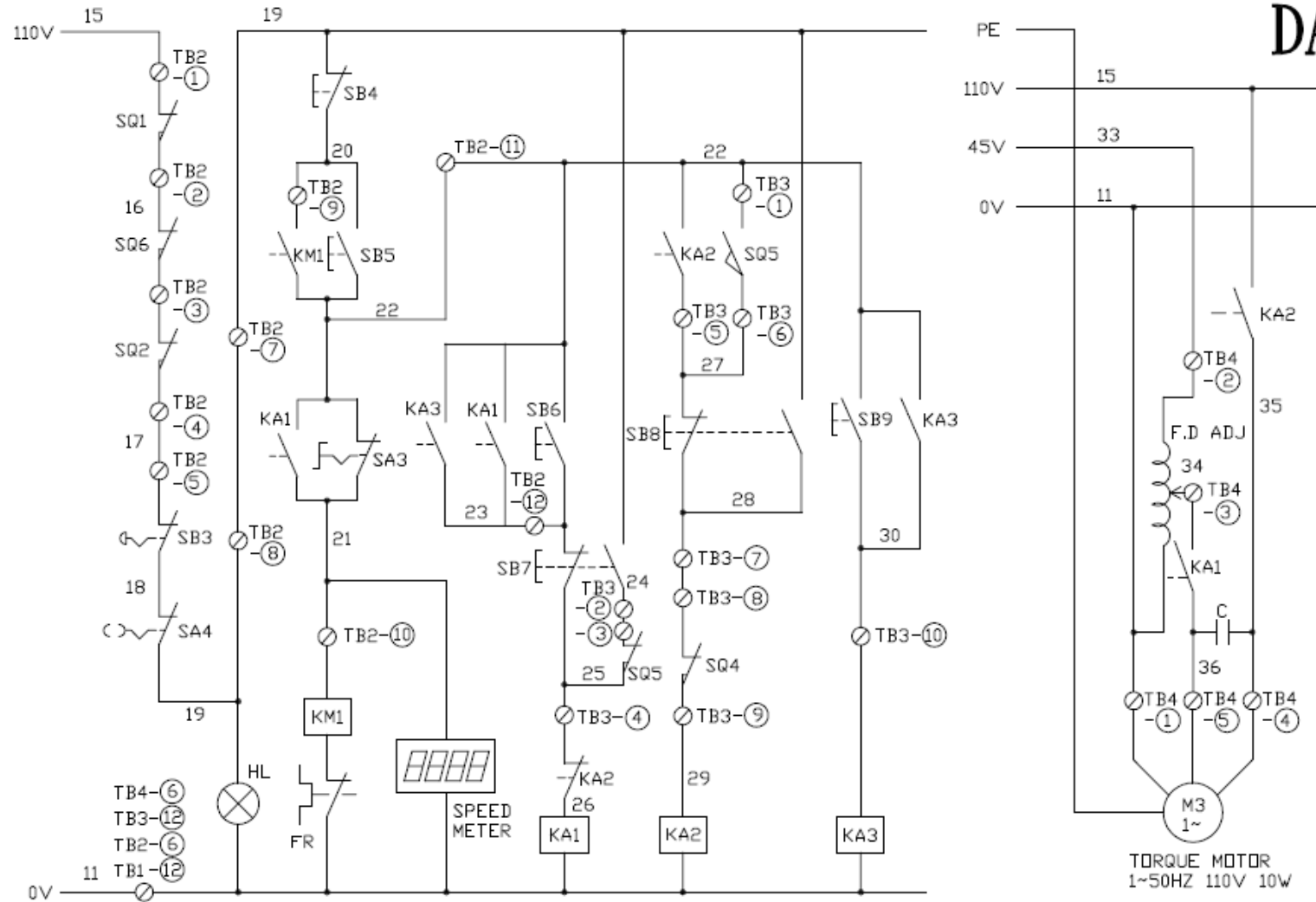

SB1	WELD ON	WHITE	SB8	REVERSE	BLACK	EL	WORK LAMP	60W,115V	SQ6	SAFETY SWITCH	36*TYPE ONLY	T1	TRANSFORMER
SB2	ANNEAL ON	GREEN	SB9	CONTINUE	GREEN	QS	MAIN SWITCH		KM1	CONTACTOR		T2	TRANSFORMER
SB3	EMERGENCY STOP	RED	SA1	GRINDER MOTOR ON		SQ1	SAFETY SWITCH		FR	OVERLOAD RELAY		FD ADJ	PRESSURE ADJUSTMENT
SB4	MAIN MOTOR OFF	RED	SA2	WORK LAMP ON		SQ2	SAFETY SWITCH		KA1	CONTACTOR RELAY		FU1-FU9	FUSE
SB5	MAIN MOTOR ON	GREEN	SA3	AUTO STOP		SQ3	WELD AUTO STOP		KA2	CONTACTOR RELAY			
SB6	AUTO	WHITE	SA4	KEY SWITCH		SQ4	TABLE SLIDE REVERSE		KA3	CONTACTOR RELAY			
SB7	FORWARD	BLACK	HL	INDICATOR LIGHT	GREEN	SQ5	TABLE SLIDE FORWARD		C	CONDENSER			