



DAKE HAND-OPERATED HYDRAULIC PRESS

Model 50H

INSTRUCTIONAL MANUAL



*Model 75H shown. May be slight differences.

WARNING!

Read and understand all instructions and responsibilities before operating. Failure to follow safety instructions and labels could result in serious injury.

Dake Corporation
1809 Industrial Park Dr
Grand Haven, MI 49417

Phone: 800.937.3253
Fax: 800.846.3253

www.dakecorp.com



TABLE OF CONTENTS

DAKE STANDARD LIMITED WARRANTY	2
RETURN & REFUND POLICY	4
SAFEGUARDING THE POINT OF OPERATION.....	5
DAKE STANDARD TERMS & CONDITIONS OF SALE	6
SPECIFICATIONS.....	7
SAFETY.....	7
SET UP.....	9
FILLING PRESS WITH OIL.....	9
OPERATION	10
CONTROLS	10
MAINTENANCE	10
LUBRICATION	10
TROUBLESHOOTING	10
PUMP PACKING LEAKAGE	10
PRESS NOT HOLDING PRESSURE.....	11
OTHER TROUBLESHOOTING.....	12
EXPLODED VIEWS & PARTS LISTS	13
ORDERING INFORMATION	17



DAKE STANDARD LIMITED WARRANTY

Finished Machines

Dake warrants to the original purchaser the finished machine manufactured or distributed by it to be free from defects in material and workmanship under normal use and service within 1 year (12 months) from the delivery date to the end user.

Parts

Dake warrants to the original purchaser the component part manufactured or distributed by it to be free from defects in material and workmanship under normal use and service within 30 days from the delivery date to the end user.

The standard limited warranty includes the replacement of the defective component part at no cost to the end user.

Sale of Service (Repairs)

Dake warrants to the original purchaser the component part repaired by Dake Corporation at the manufacturing facility to be free from defects in material and workmanship under normal use and service within 90 days from the return date to the end user, as it pertains to the repair work completed. The standard limited warranty includes repair of the defective component part, at no cost to the end user.

Warranty Process

Subject to the conditions hereinafter set forth, the manufacturer will repair or replace any portion of the product that proves defective in materials or workmanship. The manufacturer retains the sole right and option, after inspection, to determine whether to repair or replace defective equipment, parts or components. The manufacturer will assume ownership of any defective parts replaced under this warranty.

All requested warranty claims must be communicated to the distributor or representative responsible for the sale. Once communication has been initiated, Dake Customer Service must be contacted for approval:

Phone: (800) 937-3253

Email: customerservice@dakecorp.com

When contacting Dake, please have the following information readily available:

- Model #
- Serial #
- Sales Order #

Purchasers who notify Dake within the warranty period will be issued a Case number and/or a Return Material Authorization (RMA) number. If the item is to be returned per Dake's request, the RMA number must be clearly written on the exterior packaging. Any item shipped to Dake without an RMA will not be processed.



Warranty Exceptions:

The following conditions are not applicable to the standard limited warranty:

- (a) Part installation or machine service was not completed by a certified professional, and is not in accordance with applicable local codes, ordinances and good trade practices.
- (b) Defects or malfunctions resulting from improper installation or failure to operate or maintain the unit in accordance with the printed instructions provided.
- (c) Defects or malfunctions resulting from abuse, accident, neglect or damage outside of prepaid freight terms.
- (d) Normal maintenance service or preventative maintenance, and the parts used in connection with such service.
- (e) Units and parts which have been altered or repaired, other than by the manufacturer or as specifically authorized by the manufacturer.
- (f) Alterations made to the machine that were not previously approved by the manufacturer, or that are used for purposes other than the original design of the machine.



RETURN & REFUND POLICY

Thank you for purchasing from Dake! If you are not entirely satisfied with your purchase, we are here to help.

Returns

All Dake manufactured / distributed machines, parts and couplings include a 30-day return option. These policies are valid from the date of final shipment to the end user.

To be eligible for a return, the item must be unused and in the same condition as received.

All requested warranty claims must be communicated to the distributor or representative responsible for the sale. Once communication has been initiated, Dake Customer Service must be contacted for approval:

Phone: (800) 937-3253
Email: customerservice@dakecorp.com

Once the return request has been approved by Customer Service, a representative will supply a Return Material Authorization (RMA) number. The returned item must have the provided RMA number clearly marked on the outside packaging. Any item received without an RMA number clearly visible on the packaging will not be processed.

An RMA number can only be provided by the Dake Customer Service team and must be obtained prior to the return shipment.

Refunds

Once the item has been received and inspected for damages, a representative will notify the requestor referencing the provided RMA number.

If the return is approved, a refund will be issued to the original method of payment, less a 20% restocking fee. The restocking fee may be waived if an order is placed at the time of return with like-value merchandise.

Transportation costs are the responsibility of the end user and will not be credited upon return approval.

Any item that is returned after the initial 30 days or has excessive/obvious use will not be considered for a full refund.

SAFEGUARDING THE POINT OF OPERATION

ANSI B11.2 - Hydraulic Power Presses - Safety Requirements for Construction, Care, and Use

It is important that Dake press users have a clear understanding of their responsibility involving the care and use of their Dake hydraulic press, including point-of-operation safe guards. Dake strongly recommends that Dake press users obtain a copy of the current American National Standard Institute (ANSI) B11.2 standard, for a more complete understanding of their responsibilities.

ANSI B11.2 states the following, relative to point of operation safeguarding:

“Normally, only the employer (press user) can determine the requirements of the press productions system components, including the dies and methods for feeding. Therefore, the employer is ultimately responsible to designate and provide the point-of-operation safeguarding system.”

The standard also discusses additional responsibilities of the employer. Some of the key responsibilities are:

- The employer is responsible for the safety, use, and care of the hydraulic power press production system.
- The employer is responsible to consider the sources of hazards for all tasks to be implemented on the hydraulic power press production system.
- The employer is required to eliminate, or control identified hazards in the scope of their work activity.
- The employer is responsible for the training of personnel, caring for, inspecting, maintaining, and operating hydraulic press production systems to ensure their competence.
- The employer is responsible to provide and ensure that point-of-operation safeguarding is used, checked, maintained, and where applicable, adjusted on every production operation performed on a press production system.

A complete and current copy of the ANSI B.11.2 standard can be obtained by contacting the following:

American National Standards Institute
1430 Broadway
New York, NY 10018

AMT – The Association for Manufacturing Technology
7901 Westpark Drive
McLean, VA 22102



DAKE STANDARD TERMS & CONDITIONS OF SALE

All proposals and quotations for the original sale of our products are subject to the following terms and conditions:

ACCEPTANCE OF ORDER: All orders are subject to acceptance by Dake at its main office in Grand Haven, Michigan.

APPLICABLE LAWS: This quotation or acceptance shall be governed in all respects by the laws of the State of Michigan.

CANCELLATION: We reserve the right to cancel and/or refuse to complete your order if, in our opinion, you have not established credit to promptly meet the payment terms of your order. Any cancellation from the Purchaser may be subject to a 10% cancellation fee for any of our non-standard machinery upon the discretion of Dake. All custom or special quotes will not be eligible for cancellation, nor returns.

DELIVERY: The proposed shipment date is an estimate and is contingent upon causes beyond Dake's control. Under no circumstances shall Dake have any liability for loss of use or for any direct or consequential damages resulting from delay. All shipments from the Dake facilities are F.O.B.

FREIGHT CLAIM: Damage freight claims must be submitted to Dake within thirty (30) days of shipment from Dake's facility. If shipment for order was set up by the Purchaser, Dake is not liable to handle the freight claims.

PERMITS AND COMPLIANCE: Dake shall not be responsible for obtaining any permits, inspections, certifications, or licenses required for the installation or use of the equipment. Dake makes no promise or representation that the equipment or any services to be furnished by Dake will conform to any federal, state, or local laws, ordinances, regulations, codes or standards.

PRICES: Unless otherwise agreed to in writing, all prices are F.O.B. our plant in Grand Haven, Michigan and Grand Prairie, Texas. In any event, the quoted prices for component parts become invalid ten (10) days after date of quotation, and machinery may become invalid sixty (60) days after date of quotation. Unless otherwise specified in Dake's quotation, installation services and final on-site adjustments are not included in the quotation.

TAXES: Prices do not include taxes. If any sales, use or similar tax is payable to Dake in connection with any transaction or part thereof between the Purchaser and Dake with respect to goods delivered, the Purchaser will, upon demand, pay to Dake the amount of any such tax. If you are tax exempt, please include your exemption document when submitting your order.

TERMS OF PAYMENT: Terms of payment are as stated in Dake's quotation subject to credit approval by our home office. Dake will invoice Purchaser when the equipment is completed and ready for shipment. Payment terms run from invoice date. Purchaser may be required to issue a down payment before production of order and shipment, at the discretion of Dake Accounting. For credit card purchases, a 3.5% processing fee may be applicable to the order. The following states are exempt from the 3.5% processing fee: CA, CO, KS, OK, TX, FL, NY, CT, MA, and ME. Dake's preferred method of payment is as follows: ACH Wire and credit card. Checks will be accepted but may cause delay in order processing. Below is our billing address:

1809 Industrial Park Drive, Grand Haven, MI 49417

WARRANTY If, within a period of one (1) year from date of shipment, any part of any equipment sold by Dake is defective in material or workmanship and is so found after inspection by Dake, it will be replaced or repaired at the option of Dake, providing the equipment has been given normal and proper usage and is still the property of the original Purchaser. Purchased components such as Micro Drop mist system or the like, installed as a part of Dake equipment are warranted only to the extent of the original Manufacturer's warranty. Dake is not responsible for any service work performed unless authorized in advance.

THE FOREGOING WARRANTY IS EXCLUSIVE AND IN LIEU OF ALL OTHER WARRANTIES WHETHER WRITTEN, ORAL OR IMPLIED (INCLUDING ANY WARRANTY OF MERCHANTABILITY OR FITNESS FOR PARTICULAR PURPOSE). UNDER NO CIRCUMSTANCES SHALL DAKE BE LIABLE FOR ANY INCIDENTAL OR CONSEQUENTIAL DAMAGES.

SPECIFICATIONS

Number	907002	Ram travel	4"
Capacity	50 tons	Screw travel	7"
Width between uprights	32-3/4"	Horizontal work head travel	20-3/4"
Width between table channels	7-1/4"	Height	85"
Min ram to table	5"	Weight	810 lbs
Max ram to table	40"	Base	43-1/2" x 36"

In the space provided record the serial number and model number of the machine. This information is only found on the black and gold Dake tag shown below. If contacting Dake this information must be provided to assist in identifying the specific machine.



Serial No.	
Model No.	
Install Date:	

SAFETY

 **This is the safety alert symbol.** When you see this symbol on your press be alert to the potential for personal injury.

Employer is responsible to perform a hazard/PPE assessment before work activity.

Follow recommended precautions and safe operating practices.

Additional Warnings:

- **Carefully read all safety messages in these instructions and on your press safety signs.**
- Keep safety labels in good condition. Replace missing or damaged safety labels.
- Employer is responsible to perform a hazard/PPE assessment before work activity.
- Do not alter this press from its original design.
- Do not make repairs or adjustments to any hydraulic system unless you are competent or working under competent supervision.
- Only use Dake original parts.

- This machine is intended to be operated by one person. This person should be conscious of the press ram movement not only for themselves but also for persons in the immediate area of the machine.
- Tag out procedures must be followed by authorized employees as per OSHA.
- **Hydraulic** – Relieve all hydraulic pressure before servicing the press. Turn the red release handle to relieve the pressure
- **Spring Pressure** – Clamp ring on bottom of piston must be in place before removing cylinder.
- **Hoist and table channel** – always place table pins under the table channels then install the remaining pins. Always release pressure on the cable before using press.

Label Placement View

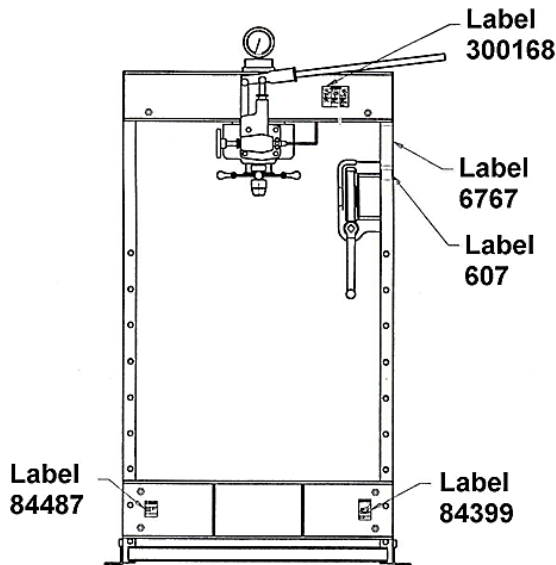

CAUTION

ALL pins must be inserted before applying any pressure
Read instructions.

CUIDADO

Todos los escálamos tienen que ser insertados ante de aplicar la presión.
Lea las instrucciones.

Label Part No. 84487

WARNING

Keep fingers out of pin holes.

PELIGRO ATENCION

No ponga los dedos en los agujeritos.

Label Part No. 84399

INSTRUCTIONS

1. FILL RESERVOIR WITH A GOOD CLEAN OIL SUCH AS MOBIL DTE® 24 OR PRODUCT OF MOBIL OIL CORPORATION. FILTER THE OIL THOROUGHLY IF FILTERED BUT AVOID LINT.

HAND PRESSES ONLY

2. REMOVE PIPE FROM TOP OF WORKHEAD. CLOSE RELEASE VALVE AND PUMP OIL INTO WORKHEAD UNTIL IT IS VISIBLE IN STANDOFF TO REMOVE AIR FROM CHAMBER ABOVE PISTON. BE SURE PISTON IS AT TOP OF ITS STROKE. AT THIS PRESSURE CHECK IN PLACE OF PIPE PLUG USING WHITE LEAD ON THREAD TO SEAL JOINT.

3. BEFORE APPLYING PRESSURE: A. LOCK WORKHEAD IN POSITION WITH UPPER HAND WHEEL. B. INSERT TABLE PINS. C. CLOSE RELEASE VALVE FIRMLY. D. LEAVE A GAP OF 1/2" BETWEEN BUMPER AND RESERVOIR. E. KEEP PORTION OF SCREW EXTENDING BEYOND RAM AS MUCH AS POSSIBLE.

4. READ INSTRUCTION SHEET FURNISHED WITH PRESS FOR FURTHER DETAILS OF OPERATION AND QUANTITY OF OIL REQUIRED.

5. IF PRESS DOES NOT HOLD PRESSURE DRAIN ALL OIL FROM RESERVOIR AND CHECK VALVES AND CLEAN OUT PORT HOLES. TAMPING HOLES. RESET VALVE PALS USING BEARS. HOLD AS A BUMP. RELEASE VALVE AND FILL RESERVOIR.

Label Part No. 6767

WARNING

Establish solid footing to prevent falls.	Keep hand away from point of operation. Read instructions.	Guard workpiece to prevent projectiles from reaching operator. Wear eye protection.

Label Part No. 300168

SERIAL NO.

DAKE

MODEL

DAKE GRAND HAVEN MICH.

Label Part No. 607

IMPORTANT

ALWAYS PUMP PISTON DOWN 1/2 INCH BEFORE NOSE PIECE COMES IN CONTACT WITH WORK. DAMAGE TO PISTON MAY OCCUR IF THIS INSTRUCTION IS NOT FOLLOWED.

Label Part No. 634



WARNING: This product contains Nickel, a chemical known to the State of California to cause cancer. For more information go to www.P65Warnings.ca.gov

SET UP

For shipping convenience, the gauge, pump handle, hoist crank, screw nose and base angles were removed from the press. Assemble these parts to the press in the following order:

1. Bolt the base angles to the uprights using the four bolts and nuts furnished. Shoulder the base angles against the stops on the uprights.
2. The press should be set on a level floor with the base angles touching the floor at all points, using shims where necessary. Then secure the base angles to the floor using four, 1/2" bolts included.
3. Install the pressure gauge using the hydraulic sealant to ensure a sealed fit.
4. Insert the pump handle into the handle socket and fasten in place by means of the set screw on top of the handle socket.
5. **CAUTION!**  Place the hoist crank on to the lift drum shaft. Remove the table pins and turn the crank to get the table to a desired height. Check to make sure the hoist cable is tracking correctly. Run the table channels from top to bottom, the cable should be on each of the two upper pulleys and should track back and forth on the cable drum.
 - a. Place the table pins under the table before releasing the hoist crank when positioning the table channels for cable tracking, servicing, or set up for desired work operating. Be sure all table pins are fully inserted in place before applying pressure. Always remove or release pressure on the cable before pressure is applied by turning the hand crank counterclockwise until slack forms in the cables. **FAILURE TO DO SO WILL CAUSE DAMAGE TO THE HOIST.**
 - b. If a tracking problem exists, contact the Dake factory for instructions.
6. Fasten nosepiece to the end of the screw using the thumbscrew included.

FILLING PRESS WITH OIL

Recommended to replace hydraulic oil every 6 months of machine use.

IMPORTANT! ONLY FILL WITH NEW, CLEAN, LIGHT HYDRAULIC OIL. UNDER NO CIRCUMSTANCES USE DIRTY OIL.

1. Use Mobil DTE 24 or equivalent.
2. Filter the oil to remove any possible dirt.
3. Put the piston in to its maximum upper position.
4. Fill the reservoir with 3 quarts of oil.
5. The press should be filled through Item No. 29 (Part No. 45388).
6. Close the release valve handwheel and pump oil into the work head until oil is visible in the standpipe.
 - a. This will remove all air from the chamber above the piston.

If oil leaks by the piston, the reservoir should be drained and refilled with the piston in the maximum upper position.

OPERATION

CONTROLS

Hand Crank: (Part No. 701653) on the side of the press is to assist in lowering and raising the table of the press once the table pins are removed. Do not forget to replace the pins once you have the table at the desired height.

Head Positioning Handwheel: can be loosened to allow the head to move along the upper frame track and can be positioned at any length on the top frame. After in position, tightening the handwheel completely will keep the head in place.

Handle: (Part No. 218) is the pressure supply source and is manually operated with up and down motion. **IMPORTANT!** Always pump the piston down 1/2" before the nose piece meets the work. Damage to the piston may occur if not pumped before meeting the work.

Release Valve Handwheel: releases the pressure to let the ram return to its raised position. Always keep the valve firmly closed when operating the press until you want to release the pressure.

Screw Handwheel: (Part No. 716519) raises or lowers the ram screw in and out of the piston assembly. Always keep the portion of the screw extending out of the piston as short as possible. Instead of overextending the screw it is recommended to raise the table rather than running the screw out of its limit of travel. **NEVER EXCEED THE RECOMMENDED STROKE OF 4 INCHES FOR THIS PRESS. EXCEEDING THE STROKE WILL CAUSE DAMAGE TO THE INNER PACKINGS.**

MAINTENANCE

Recommended to replace hydraulic oil every 6 months of machine use.

LUBRICATION

- Keep all working parts of the press well-oiled for easier operation.
- Keep a light film of oil over the entire surface of the ram to prevent rust.

TROUBLESHOOTING

PUMP PACKING LEAKAGE

If oil leaks past the pump packing, tighten the pump packing nut (Part No. 551A) until the pump handle moves with resistance, then slack off just enough to cause the handle to stay in position by itself. After long periods of operation, it may be necessary to install new pump packings.

PRESS NOT HOLDING PRESSURE

This condition is nearly always caused by dirt under the pressure ball valve (Part No. 586). See hand pump assembly drawing.

Steps to fix:

1. Remove the reservoir drain plug and drain all oil out of the reservoir.
2. Remove parts: pipe plug (Part No. 588), check valve spring (Part No. 579) and ball valve (Part No. 586) then clean out the port hole and valve seat thoroughly.
3. Using a small piece of brass rod as a drift, tap on the brass rod lightly to seat the ball valve in place.
4. Replace the spring and plug with extreme care to prevent dirt from entering.
5. Replace the drain plug and refill the reservoir with clean filtered oil.

See **FILLING PRESS WITH OIL** section in manual.

OTHER TROUBLESHOOTING

SYMPTOM	CAUSE	SOLUTION
Oil leaking from piston oil seal.	<ol style="list-style-type: none"> 1) Reservoir is over filled. (Item 22) 2) Piston Packing is worn or damaged. (Part No. 573) 	<ol style="list-style-type: none"> 1) Drain excess oil. 2) Replace Piston Packing.
Press will not hold pressure.	<ol style="list-style-type: none"> 1) Check Ball (Part No. 586) is contaminated. 2) Ball and Seat have poor contact. (Part No. 586) 3) Piston Packing is worn or damaged. (Part No. 573) 	<ol style="list-style-type: none"> 1) Remove and clean Check Balls and Seats. 2) Reseal Ball on Seat. 3) Replace Piston Packing
Press will not build rated tonnage.	<ol style="list-style-type: none"> 1) Pump Plunger leather is worn or damaged. (Part No. 554) 2) Check Ball is contaminated. (Part No. 573) 3) Ball and Seat have poor contact. (Part No. 586) 4) Piston Packing is worn or damaged (Part No. 573) 5) Gauge is defective. (Part No. 71266) 	<ol style="list-style-type: none"> 1) Replace Pump Plunger leather. 2) Remove and clean Check Balls and Seats. 3) Reseal Ball on Seat. 4) Replace Piston Packing. 5) Replace Gauge.
Oil leaking from pump plunger.	<ol style="list-style-type: none"> 1) Packing Nut loose. (Part No. 551) 2) Worn Packings 	<ol style="list-style-type: none"> 1) Tighten Packing Nut. 2) Replace Pump Packings.
Oil leaking from release valve rod.	<ol style="list-style-type: none"> 1) Valve Rod Packing Nut is Loose (Part No. 978) 2) Packings are worn. 	<ol style="list-style-type: none"> 1) Tighten Packing Nut. 2) Replace Valve Rod Packings.
Pump handle drifts up.	<ol style="list-style-type: none"> 1) Defective Check Ball. (Part No. 586) 2) Defective Check Ball Spring. (Part No. 579) 	<ol style="list-style-type: none"> 3) Clean Check Ball and reseal. 4) Replace Spring.
Ram will not return.	<ol style="list-style-type: none"> 1) Return Spring damaged. (Part No. 556) 2) Piston is bent or damaged. (Part No. 543) 3) Piston Packing is defective. 	<ol style="list-style-type: none"> 1) Replace Spring. 2) Replace Piston. 3) Replace Piston Packing
*If oil leaks from around ram but there is no pressure loss than the reservoir has been overfilled		

EXPLODED VIEWS & PARTS LISTS

HAND PUMP ASSEMBLY

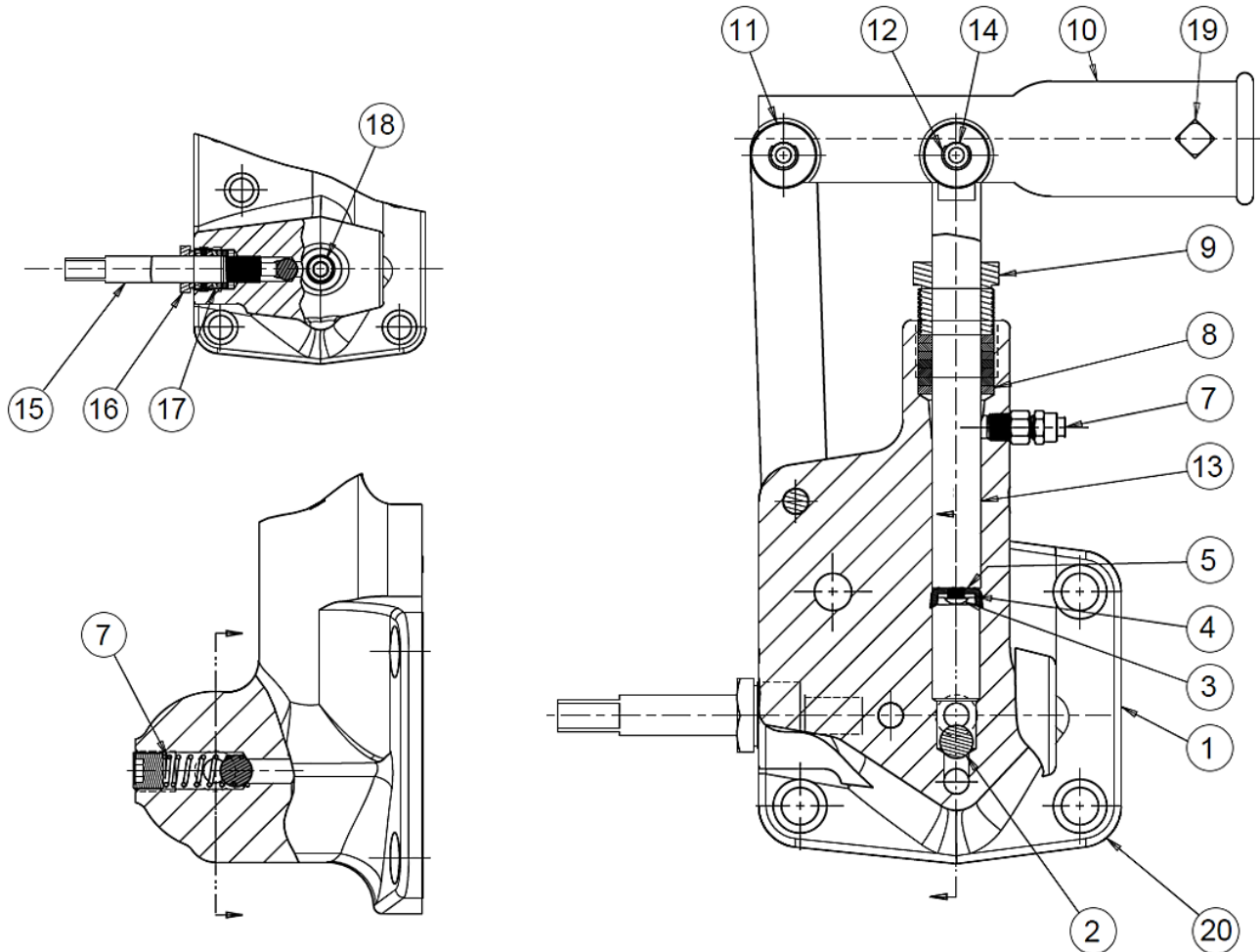

Item No.	Part Name	Part No.	Qty
1	Pump Body	546	1
2	Ball Valve (Ø1/2")	586	3
3	Hex Cap Screw (1/4"-20 x 1/2" Nylock)	28297	1
4	Washer (#12 Flat)	43629	1
5	Pump Plunger Leather	599	1
6	Check Valve Spring	579	1
7	Tube Fitting	71413	1
8	Pump Packing	573	7
9	Pump Packing Nut	551A	1
10	Handle Socket	550	1
11	Handle Socket Link	555	1

Item No.	Part Name	Part No.	Qty
12	Retaining Ring (3/8")	43972	6
13	Pump Plunger	554	1
14	Handle Socket Pin	594	3
15	Valve Rod	1129	1
16	Valve Rod Packing Nut	576	1
17	Valve Rod Packing	987	8
18	Pipe Plug (3/8")	588	1
19	Set Screw (3/8"-16 x 5/8")	43589	1
20	Pump Gasket	591	1
Hand Pump Complete Assembly		700887	-
Repair Kit- Cylinder & Hand Pump Assembly (Items: 5, 8, 17, 20, 26B, 27, 34, 38)		701291	-

WORKHEAD ASSEMBLY

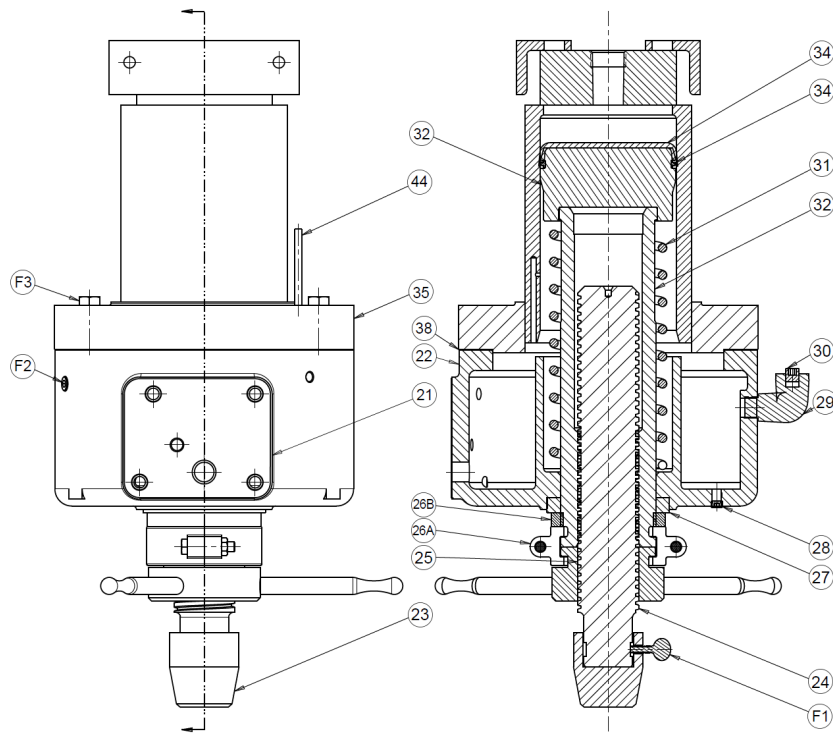

Item	Part Name	Part No.	Qty	Item	Part Name	Part No.	Qty
21	Pump Gasket	591	1	32	Piston Assembly (Serial No. > 192523)	716222	1
22	Reservoir	540	1	34	Piston Leather (Serial No. < 192522)	557	1
23	Screw Nose – Flat	572	1	34	Packing Ring (Serial No. > 192523)	17878	1
	Screw Nose – V-Ram	344	1	35	Cylinder	536	1
24	Screw – 50H	559	1	38	Cylinder Gasket	1268	1
25	Handwheel	716519	1	44	Air Vent Tube (1/4" x 3")	632	1
26A	Clamp Ring Assembly	717	1	F1	Thumb Screw	43618	1
26B	Piston Bumper	605	1	F2	Pipe Plug (1/4" NPTF)	1567	1
27	Oil Seal	1267	1	F3	Hex Head Cap Screw (1/2"-13 x 2-1/4")	43352	4
28	Pipe Plug (1/8" NPTF)	589	1	F4/F5	Pipe Plug (1/4") NPTF	1567	1
29	Elbow Pipe Plug	45388	1	F5/F4	Hex Nut (3/8"-16)	43912	2
30	Pipe Plug (1/2" NPTF)	596	1	F6/56	Hex Cap Screw (2-3/4 x 3/8"-16)	43335	2
31	Ram Spring	556	1		Complete Workhead Assembly	907007	
32	Piston Assembly (Serial No. < 192522)	701801	1		Repair Kit – Cylinder & Hand Pump Assembly (Items: 5, 8, 17, 20, 26B, 27, 34, 38)	701291	

GENERAL ASSEMBLY

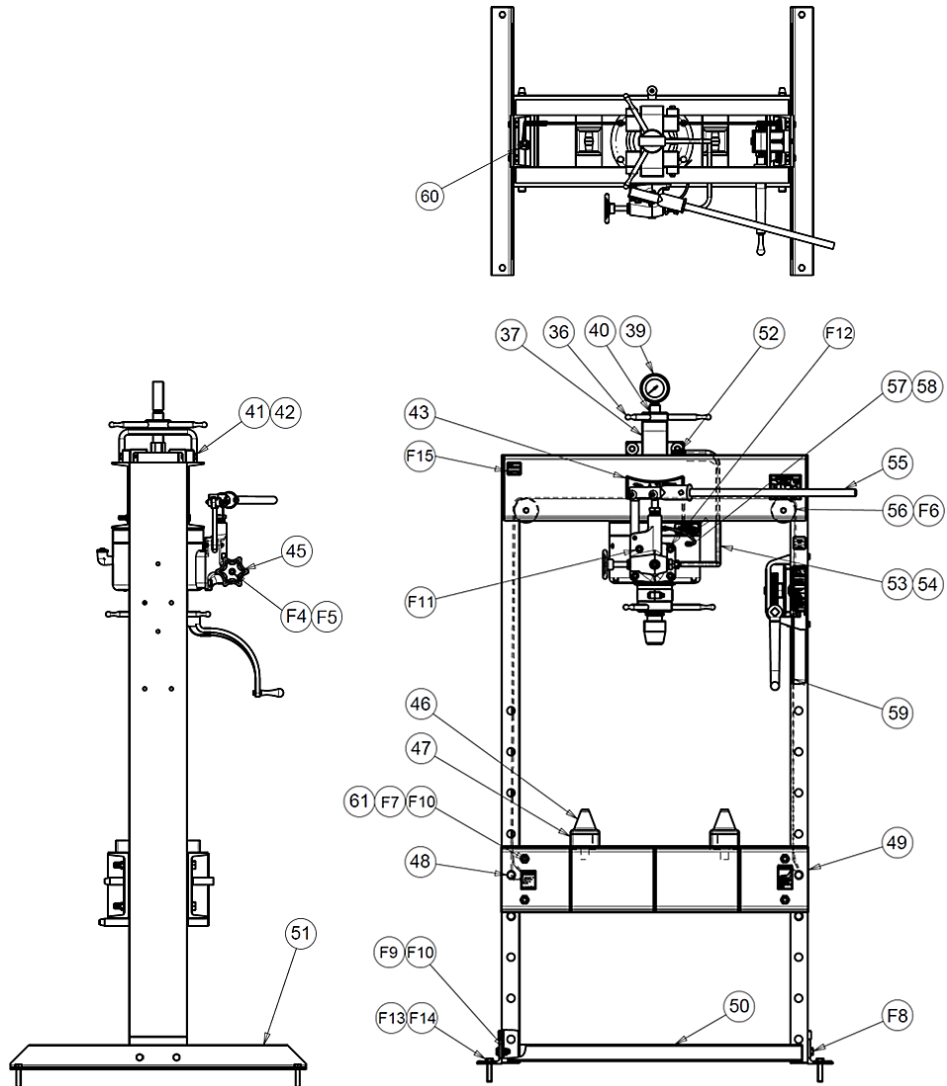

GENERAL ASSEMBLY PARTS LIST

Item No.	Part Name	Part No.	Qty
36	Screw Adjusting Wheel	716521	1
37	Yoke	593	1
39	Gauge	71266	1
	Bushing	81384	1
40	Gauge Extension	731	1
41	Roller	592	4
42	Roller Screw	595	4
43	Dake Name Plate	81002	1
45	Handwheel	10631	1

Item No.	Part Name	Part No.	Qty
56	Pulley	602	2
	Pulley Bolt	43342	2
	Hex Nut (3/8"-16)	43912	2
57	Vent Tube	67761	1
58	1/8" NPT Fitting	71413	2
59	Cable	580	1
60	Cable Clamps	991	4
61	Table Spacer	86486P	4
61a	Includes 61, F7, F9, F10	716692	
F4	Flat Washer (1/4")	43631	1

46	V-Block	336	2
47	Table Plate	545	2
48	Table Pins	569	4
48A	Safety Pin	302816	4
48B	Retaining Ring	43980	4
-	48 + 48B	716899	-
49	Table Channel	701091	2
50	Frame only	700116	1
51	Base Angle	566	2
52	3/8" NPT 37° Fitting	1251	2
53	Fitting Nut	46614	2
	Fitting Sleeve	51454	2
54	Tube Assembly (Includes 53 & 54)	700117	1
55	Handle	218	1

F5	Bolt (1/4"-20 x 1/2")	43301	1
F6	Pulley Lock Washer (3/8")	43645	2
F7	Bolt (5/8"-11 x 9-1/2")	79981	4
F8	Hex Cap Screw (1/2"-13 x 1-1/4")	43348	4
F9	Lock Washer (1/2")	43647	4
F10	Hex Nut (1/2"-13)	43916	8
F11	Socket Cap Screw (1/2"-14 x 2-1/2")	24561	1
F12	Socket Cap Screw (1/2"-13 1-1/4')	43470	3
F13	Washer (1/2")	43634	4
F14	Lag Screw	72355	4
F15	Label – Made in USA	76936	1

TABLE HOIST ASSEMBLY

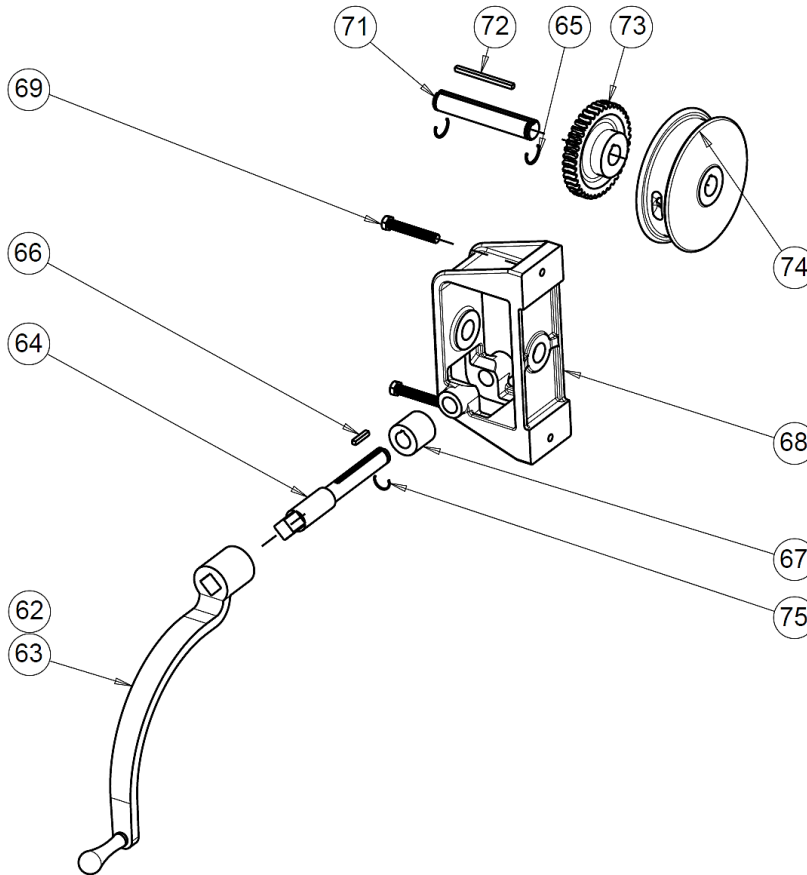

Item No.	Part Name	Part No.	Qty
56	Hex Nut (3/8"-16) (Not Shown)	43912	2
62	Hand Crank Assembly	701653	1
63			
64	Worm Shaft	384	1
65	Retaining Ring	27437	2
66	Worm Key	47364	1
67	Worm	385	1
68	Hoist Frame	725	1

Item No.	Part Name	Part No.	Qty
69	Hex Cap Screw (3/8"-16 x 2-3/4")	43335	2
71	Drum Shaft	724	1
72	Drum Key	737	1
73	Worm Gear	736	1
74	Cable Drum	723	1
75	Retaining Ring	43992	1
	Complete Table Hoist Assembly - Includes Crank	700112	-

Please contact factory for current prices.

ORDERING INFORMATION



Dake Corporation
1809 Industrial Park Dr
Grand Haven, MI 49417
www.dakecorp.com

Parts are available for direct purchase from Dake or through a distributor. When placing a parts order, you will need to provide the part number, name of part, and model number. All parts shipped F.O.B. Factory in Grand Haven, MI.