



SXC Dake Bandsaw

INSTRUCTIONAL MANUAL



⚠ WARNING! Read and understand all instructions and responsibilities before operating.
Failure to follow safety instructions and labels could result in serious injury.

TABLE OF CONTENTS

DAKE STANDARD LIMITED WARRANTY	3
RETURN & REFUND POLICY	5
SPECIFICATIONS	6
SAFETY WARNINGS	7
ADJUSTMENTS	8
BLADE SELECTION	9
Blade Speeds: (FPM) & Removal/Install Procedure.....	9
LUBRICATION	9
ELECTRICAL DIAGRAMS	10
EXPLODED VIEWS & PARTS LISTS	14
Gear Assembly Parts List.....	15
ORDER INFORMATION	19

DAKE STANDARD LIMITED WARRANTY

Finished Machines

- Dake warrants to the original purchaser the finished machine manufactured or distributed by it to be free from defects in material and workmanship under normal use and service within **1 year (12 months) from the delivery** date to the end user.

Parts

- Dake warrants to the original purchaser the component part manufactured or distributed by it to be free from defects in material and workmanship under normal use and service within **30 days** from the delivery date to the end user.
- The standard limited warranty includes the replacement of the defective component part at no cost to the end user.

Sale of Service (Repairs)

- Dake warrants to the original purchaser the component part repaired by Dake Corporation at the manufacturing facility to be free from defects in material and workmanship under normal use and service within 90 days from the return date to the end user, as it pertains to the repair work completed.
- The standard limited warranty includes repair of the defective component part, at no cost to the end user.

Warranty Process

- Subject to the conditions hereinafter set forth, the manufacturer will repair or replace any portion of the product that proves defective in materials or workmanship. The manufacturer retains the sole right and option, after inspection, to determine whether to repair or replace defective equipment, parts, or components. The manufacturer will assume ownership of any defective parts replaced under this warranty.
- All requested warranty claims must be communicated to the distributor or representative responsible for the sale. Once communication has been initiated, Dake Customer Service must be contacted for approval:
 - Phone: (800) 937-3253
 - Email: customerservice@dakecorp.com

- When contacting Dake, please have the following information readily available:
 1. Model #
 2. Serial #
 3. Sales Order #

- Purchasers who notify Dake within the warranty period will be issued a Case number and/or a Return Material Authorization (RMA) number. If the item is to be returned per Dake's request, the RMA number must be **clearly** written on the exterior packaging. Any item shipped to Dake without an RMA will not be processed.

Warranty Exceptions

The following conditions are not applicable to the standard limited warranty:

- (a) Part installation or machine service was not completed by a certified professional, and is not in accordance with applicable local codes, ordinances, and good trade practices.
- (b) Defects or malfunctions resulting from improper installation or failure to operate or maintain the unit in accordance with the printed instructions provided.
- (c) Defects or malfunctions resulting from abuse, accident, neglect, or damage outside of prepaid freight terms.
- (d) Normal maintenance service or preventative maintenance, and the parts used in connection with such service.
- (e) Units and parts which have been altered or repaired, other than by the manufacturer or as specifically authorized by the manufacturer.
- (f) Alterations made to the machine that were not previously approved by the manufacturer, or that are used for purposes other than the original design of the machine.

RETURN & REFUND POLICY

- Thank you for purchasing from Dake! If you are not entirely satisfied with your purchase, we are here to help.

Returns

- All Dake manufactured / distributed machines, parts and couplings include a 30-day return option. These policies are valid from the date of final shipment to the end user. To be eligible for a return, the item must be unused and in the same condition as received.
- All requested warranty claims must be communicated to the distributor or representative responsible for the sale. Once communication has been initiated, Dake Customer Service must be contacted for approval:
 - Phone: (800) 937-3253
 - Email: customerservice@dakecorp.com
- Once the return request has been approved by Customer Service, a representative will supply a Return Material Authorization (RMA) number.
- The returned item must have the provided RMA number clearly marked on the outside packaging. Any item received without an RMA number clearly visible on the packaging will not be processed.
- An RMA number can only be provided by the Dake Customer Service team and must be obtained prior to the return shipment.

Refunds

- Once the item has been received and inspected for damages, a representative will notify the requestor referencing the provided RMA number. If the return is approved, a refund will be issued to the original method of payment, less a 20% restocking fee.
- The restocking fee may be waived if an order is placed at the time of return with like-value merchandise. Transportation costs are the responsibility of the end user and will not be credited upon return approval.
- Any item that is returned after the initial 30 days or has excessive/obvious use will not be considered for a full refund.

SPECIFICATIONS

Machine Type	Gravity feed, rolling frame vertical bandsaw	Band Wheels	14" Diameter
Cut Capacity	9 inches x 14-½ inches	Horsepower	1 H.P.
Blade (frame) Travel	9 inches	Weight	810 pounds
Frame Travel	Gravity counterbalance weight with hydraulic regulation	Overall Height	66"
Maximum work height	14-1/2 inches	Base Width	29"
Blade Width/Length	1/4 – 3/4 inches / 120 inches	Depth	40"
Blade Speeds (Feet per Minute)	70 / 140 / 270 / 540 FPM	Voltage	120-volt single phase 230-volt single phase 230-volt three phase 460-volt three phase Machine should be wired to main service by a qualified Electrician
Worktable Dimensions	29" x 18"	AMP	• 20-amp service for 120-volt & 230-volt machines • 16-amp service for 460-volt machine
Mitering	45°		
Worktable Height from Floor	36-1/2"		

Machine Features:

- Roller blade guides, miter gauge with C-Clamp assembly, headlock, cutting chart, and one standard blade furnished with the machine.
- Large precision ground table for large work surface.
- Heavy-duty gearbox with 4 speed step pulleys for fast speed changes.
- 14" lipped band wheels with rubber tires for smooth operation and long life.
- Blade changes are made quickly with easy access to the band wheels.
- Welded steel base and head frame that is rigid, heavy and durable that helps reduce any wobble and vibration.
- Adjustable counterweight and infinitely variable hydraulic feed pressure regulation, for hands free cutting of most materials.
- Front mounted hydraulic feed control for operator convenience and operation.
- Electrical package that includes low voltage controls, low voltage coil and E-stop button.
- Heavy cast miter gauge and C-Clamp for holding material during the cutting operation, whether it is straight or miter cutting.

In the space provided record the serial number and model number of the machine. This information is only found on the black Dake tag. If contacting Dake this information must be provided to assist in identifying the specific machine.

Model No: _____

Part No: _____

Serial No: _____

Date of Purchase: _____

SAFETY WARNINGS

BEFORE USE, ALL SAFETY INSTRUCTIONS MUST BE READ

- Before the PRESS is used, the instruction manual with this machine must be read and understood. This manual offers safe operation instructions. Offered below are safety instructions designed for the press and general safety instructions that apply to most machinery.
- As with all machinery there are certain hazards involved with operation and use of the machine. Using the machine with respect and caution will considerably lessen the possibility of personal injury. However, if normal safety precautions are overlooked or ignored, personal injury to the operator may result.
- This machine was designed for certain applications only. We strongly recommend that this machine NOT be modified and/or used for any application other than for which it was designed. If you have any questions relative to its application DO NOT use the machine until you contact with us and we have advised you to do so.

Practice Safe Operation:

- Keep hands out of point of operation.
- Never wear cloth gloves.
- Always wear the eye protection.
- Look over machine for general maintenance before operation task.
- Keep all body parts as far away from the moving blade as possible.
- Always use the correct specified blade type and correct length.
- Never force the work into the blade to speed up the process. Allow the blade to do the cutting.
- Always have firm footing when operating the saw and have an open surrounding.
- Do not modify or change the structure of the saw. It is designed the way it is for a reason.

Safety Labels:



Part # 84395

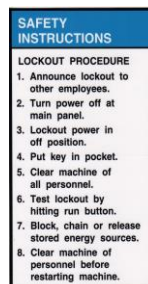

Part # 84605



Part 84605

ADJUSTMENTS

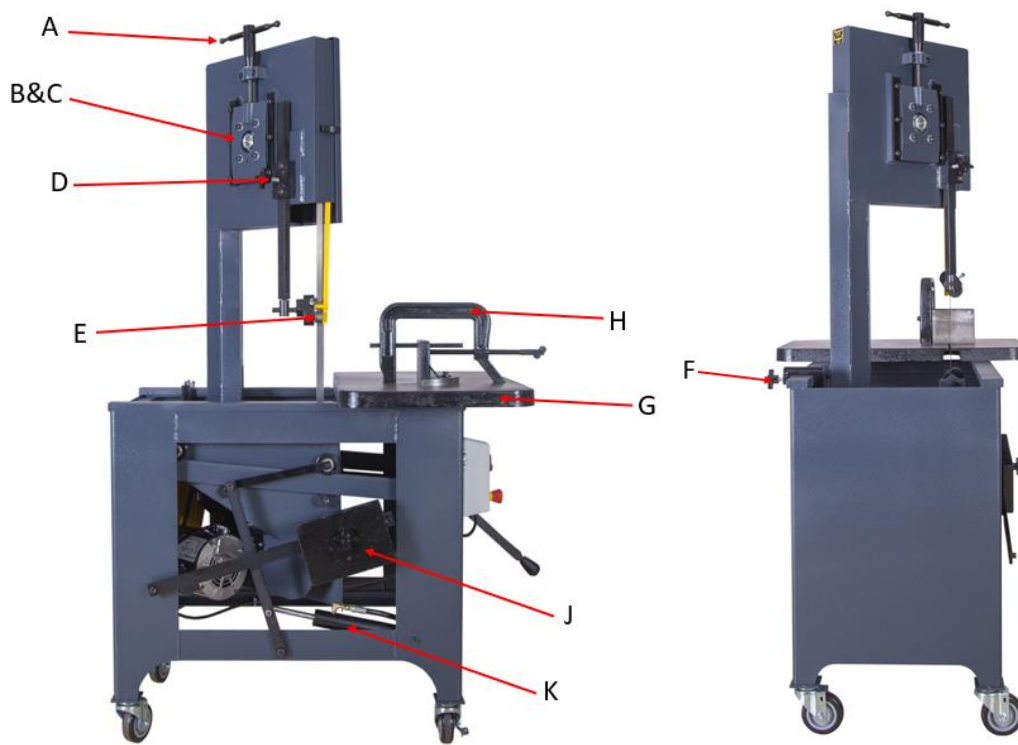

- A:** BLADE TENSION HANDLE – Used to remove and install saw blade. Also used to set the correct blade tension – Be sure blade is tight.
- B&C** UPPER BLADE WHEEL CONT ADJUSTMENT – If your saw should get out of adjustment and the blade runs off the wheel or runs back against the lip, loosen the two bottom bolts on the wheel slide (B) Turn the set screw (C) in or out to make the blade run approximately 1/32” away from the lip on the back of the wheel. Tighten the two wheel slide bolts. **IMPORTANT: If the blade is allowed to run against the lip on the wheel it will wear the lip off.**
- D** GUIDE BAR LOCK – Used to lock the roll guides in position.
- E** ROLL GUIDES – Should be adjusted so they clear your work by approximately 1/2”. This will insure maximum blade rigidity.
- F** STOP CLAMP – Has two uses: 1) The stop clamp can be set for depth of cut. 2) The stop clamp, if placed behind the neck, will lock the frame in a forward position for contour work.
- G** ANGLE PLATE – Used to hold stock in place for cutting. Graduations are provided to set angle cuts.
- H** C-CLAMP – Used mainly for round stock. Flat stock needs no clamping.
- J** COUNTERWEIGHT – Used to maintain the blade pressure you desire.
- K** HYDRAULIC CYLINDER – This should be adjusted to allow the frame to travel rapidly but not free fall. **This is a safety device and should be kept properly adjusted.**

BLADE SELECTION

- For operator convenience, a blade selector chart is located inside the saw cover. It provides recommended blade speeds, required teeth per inch, and minimum cutting radius for various blade widths. The following chart can be used to select the blade needed:

Thickness of Material	Teeth per Inch
Up to 1/8"	18T
1/8" to 1/4"	14T
1/4" to 1/2"	10T
1/2" to 1"	8T
1" to 3"	6T-4T
3" to 6"	4T-6T
6" and longer	3H

Blade Speeds: (FPM) & Removal/Install Procedure

- To change blade speeds, bring the frame all the way forward. Lift the motor and move the V-belt to one of the three speeds offered: 70, 140, 270, or 540. Refer to the blade selector chart inside the cover on your SXC for the appropriate speed.
- To remove the blade, release the blade tension handle then remove the blade.
- To install blade, place the blade over the bottom wheel, then on the top wheel. Teeth must point down toward the table. Tighten the blade tension handle enough to hold the blade firmly in place, and then push the blade into the roller guides. Turn the machine on to allow the blade to position itself, and then finish tightening the blade.

Please Note: The most common causes of the SXC not cutting straight are:

- 1) Blade tension is too low.
- 2) Blade is dull or worn on one side.
- 3) Blade was installed upside down. The teeth must point down toward the table.

LUBRICATION

- **Gear Box:** Your SXC gearbox is filled at the factory. Check the fluid level on arrival, and then check every six months thereafter. Use 90-weight gear lube to maintain fluid level at the fill/check pipe plug.
- **Cylinder:** Keep the cylinder reservoir 1/2 to 3/4 full. Use light hydraulic oil to refill.

ELECTRICAL DIAGRAMS

110V

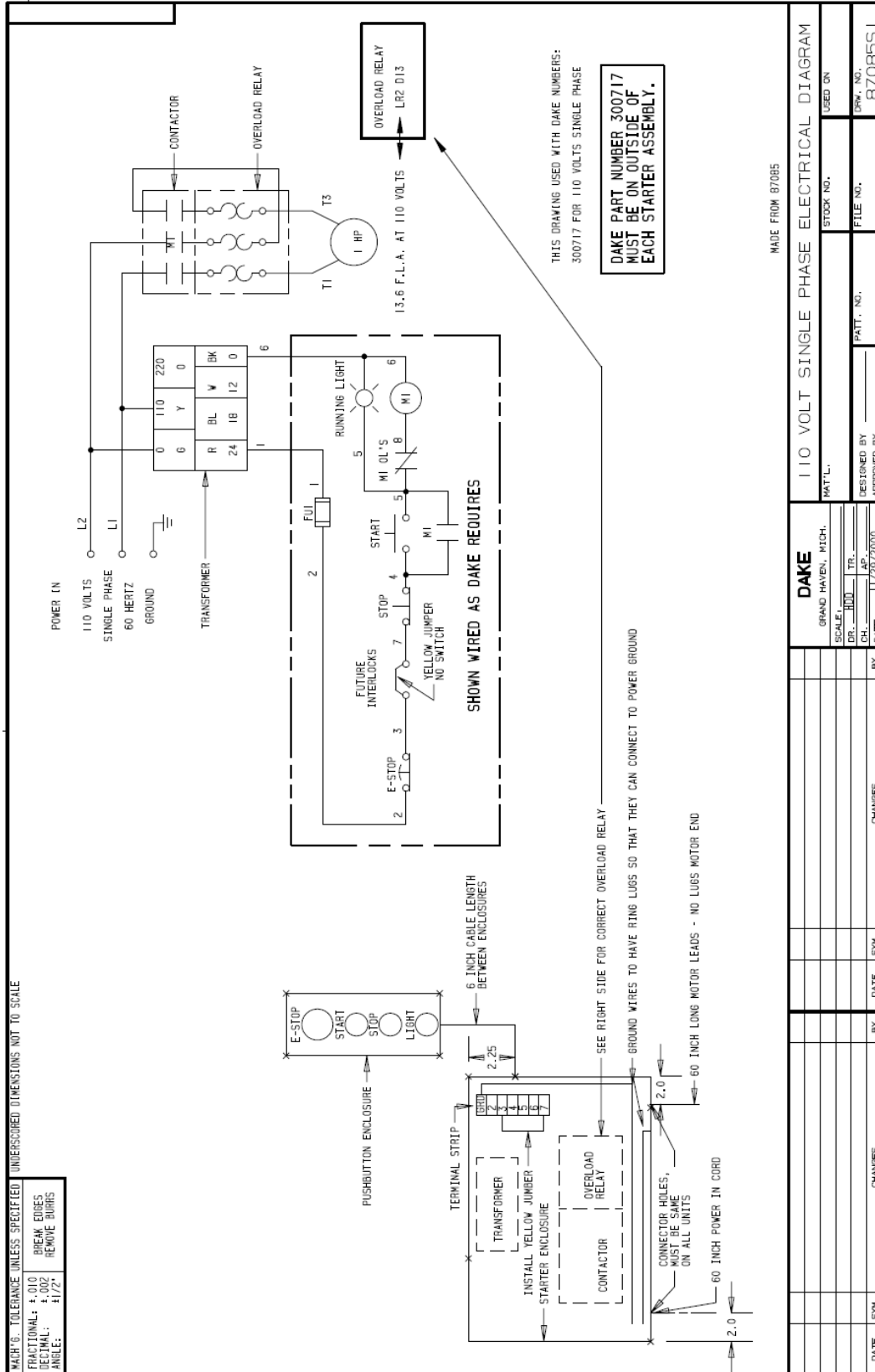

DAKE		110 VOLT SINGLE PHASE ELECTRICAL DIAGRAM	
GRAND HAVEN, MICH.	MAT'L.	STOCK NO.	USED ON
SCALE: _____	DESIGNED BY _____	FILE NO.	87085S1
DR. _____	APPROVED BY _____	PART. NO.	
CH. _____	DATE: 11/29/2000		
BY _____	CHANGES	DATE	SYN.
	CHANGES		

220V Single Phase

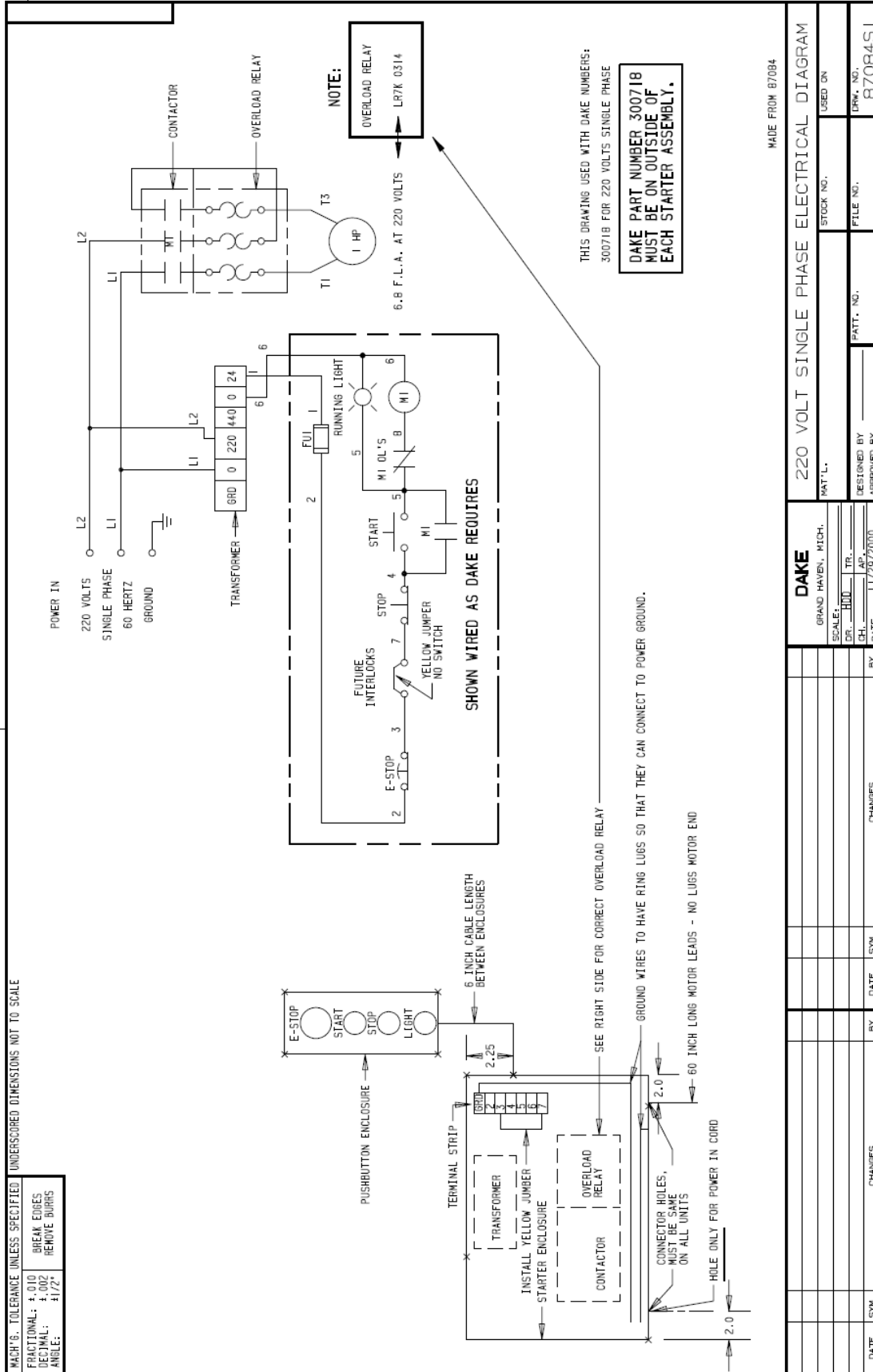

230V 3-Phase

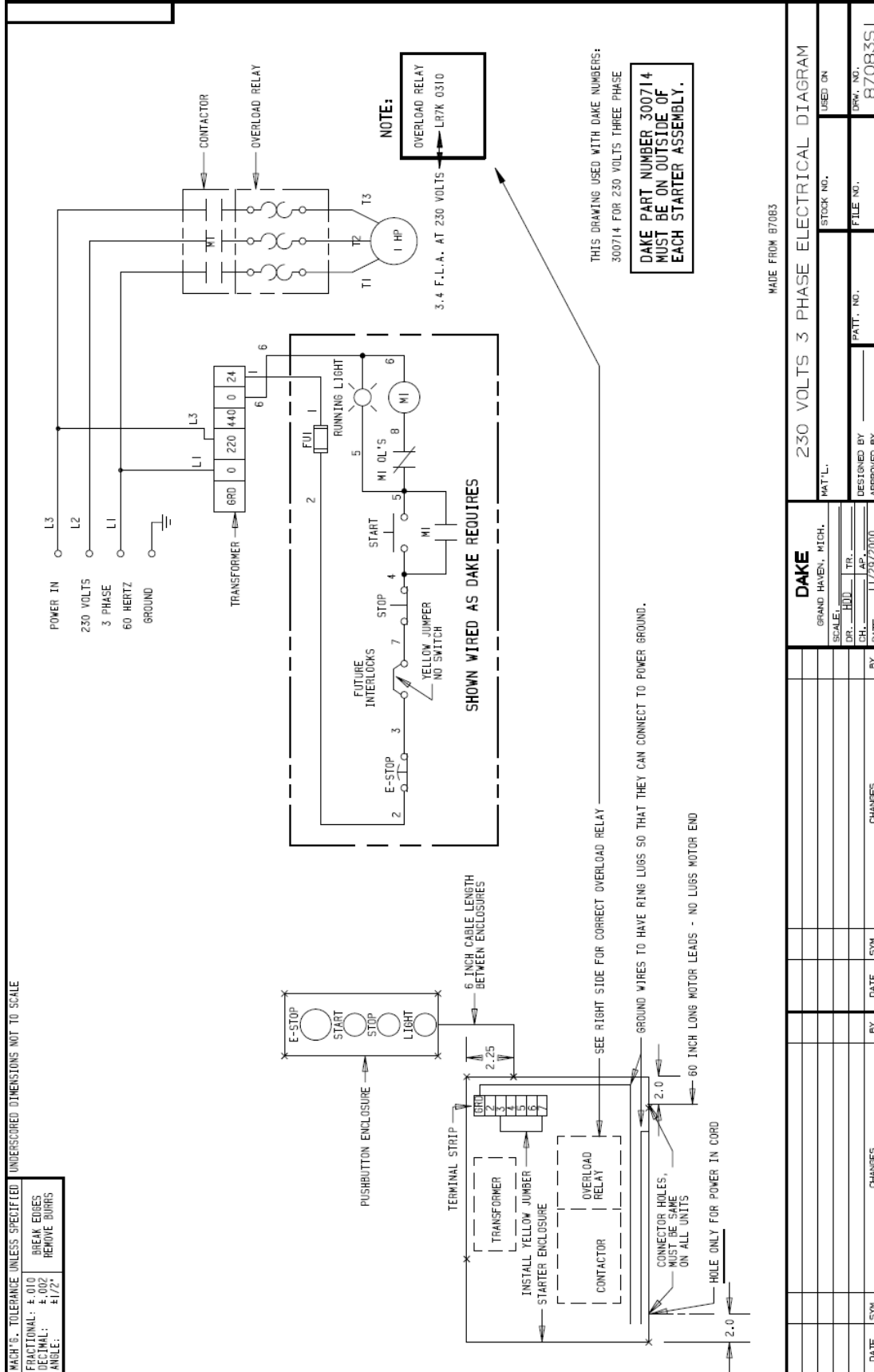

MACH'G. TOLERANCE UNLESS SPECIFIED: UNDESIGNED DIMENSIONS NOT TO SCALE
FRACTIONAL: ±.010 BREAK EDGES
DECIMAL: ±.002 REMOVE DIMS
ANGLE: ±1/2°

DATE	SYN.	CHANGES	BY	DATE	SYN.	CHANGES
<div style="display: flex; justify-content: space-between;"> <div> <p>DAKE GRAND HAVEN, MICH. SCALE: _____ DR: HJD TR: _____ CH: _____ AP: _____ DATE: 11/29/2000</p> </div> <div> <p>DESIGNED BY: _____ APPROVED BY: _____</p> </div> </div>						
230 VOLTS 3 PHASE ELECTRICAL DIAGRAM			STOCK NO.	FILE NO.	DRAW. NO. B70835 I	

460V 3-Phase

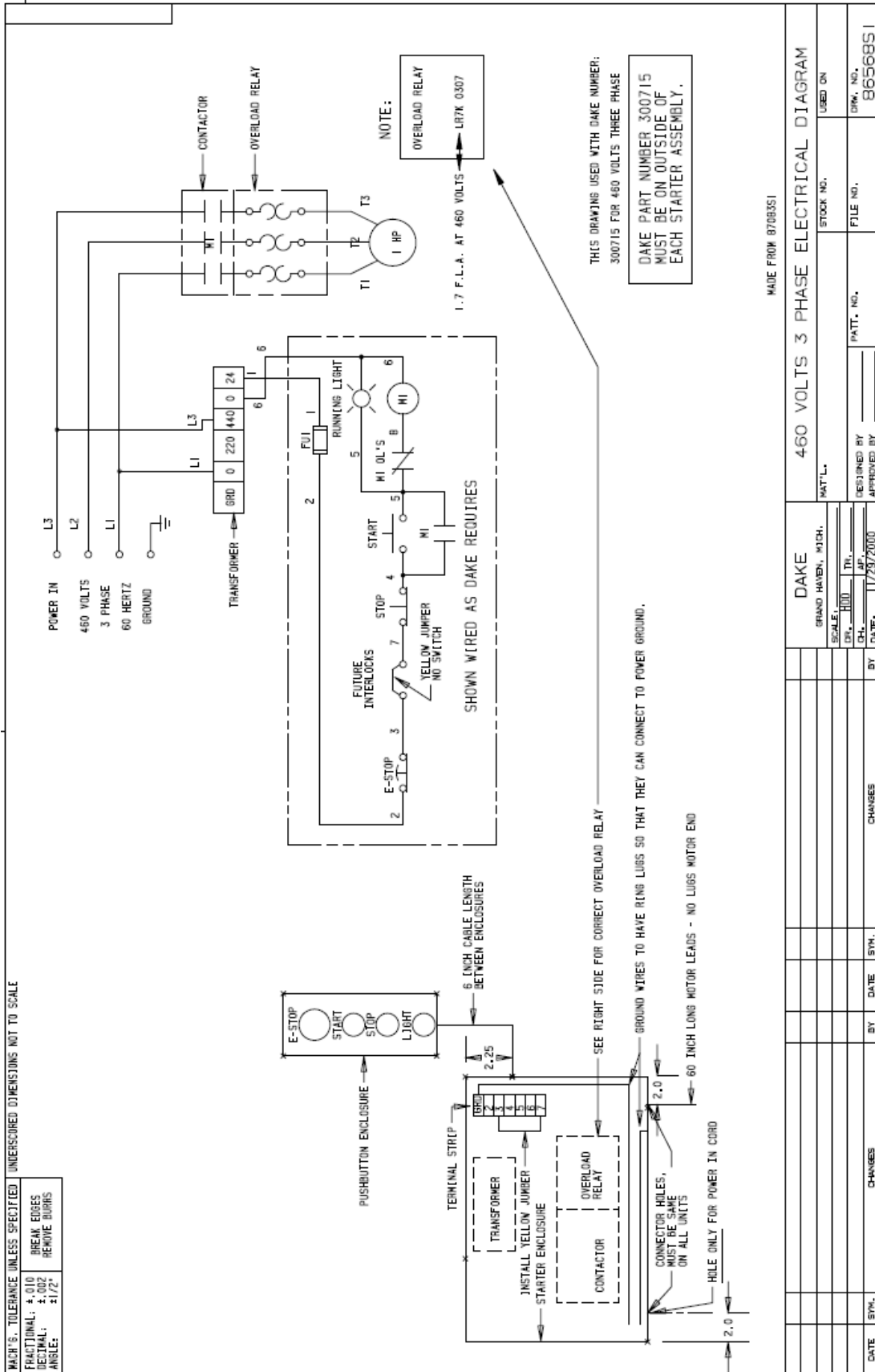

EXPLODED VIEWS & PARTS LISTS

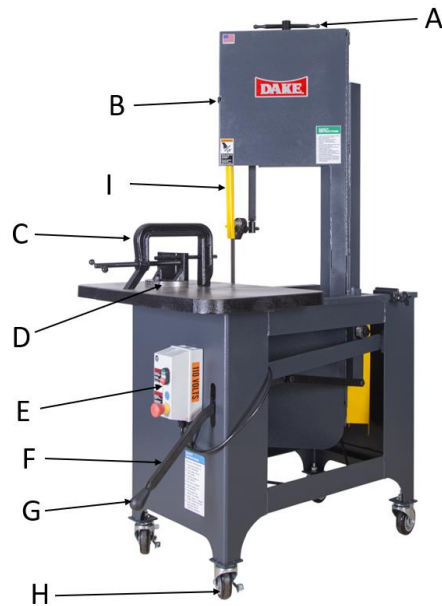

Item	Part Number	Description	Qty
A	716716	Tension Handle Assembly	1
B	86747	Door Latch	1
C	716714	C-Clamp Assembly	1
D	716703	Angle Plate with Pin	1
E1	716764	New Style Complete Electrical Kit – 1 ph 110 volt	1
E2	716765	New Style Complete Electrical Kit – 1 ph 220 volt	1
E3	716766	New Style Complete Electrical Kit – 3 ph 230 volt	1
E4	716767	New Style Complete Electrical Kit – 3 ph 460 volt	1
F	86782	Return Handle	1
G	300450	Knob, Return Handle	1
H	716725	Caster Set - Optional	1
I	87093	Blade Guard	1

Gear Assembly Parts List

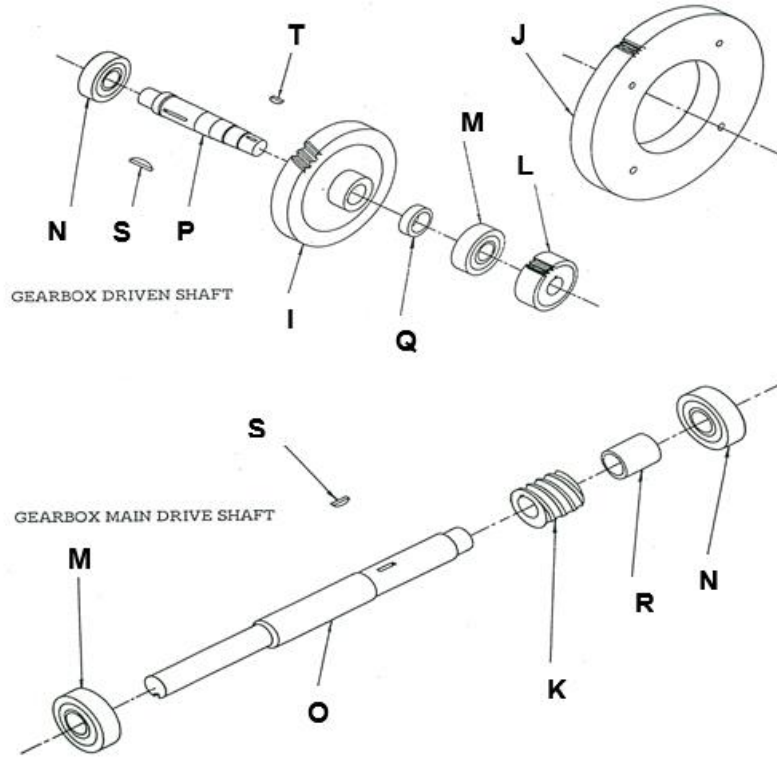

Item	Part Number	Description	Quantity
	716712	Gearbox Assembly	1
	300472	Bearing, Seal	2
	300490	Gasket, Gearbox	1
	300491	Gasket, Gearbox	4
	300589	Dowel Pin 3/16 x 1/2	2
	43412	Screw, Soc Cap	16
	43414	Screw, Soc Cap	6
	43590	Screw, Soc Set	3
	86820	Bearing Cover, Small/hole	2
	86821	Bearing Cover, Small	2
	86822	Gearbox Casting	1
	86823	Cover, Gearbox	1
I	300666	Gear, Worm 40T Bronze	1
J	86784	80 Tooth Gear	1
K	300456	Worm, 4-Lead	1
L	300646	24 Tooth Gear	1
M	5072-00	Bearing, Gearbox	2
N	5073-00	Bearing, Gearbox	2
O	86785	Shaft, Main Drive	1
P	86781	Axle, Gearbox-Short	1
Q	86783	Spacer, Gearbox 1-1/4	1
R	86786	Spacer, Gearbox	1
S	300449	Key, Woodruff #13	2
T	300451	Key, Woodruff #5	1

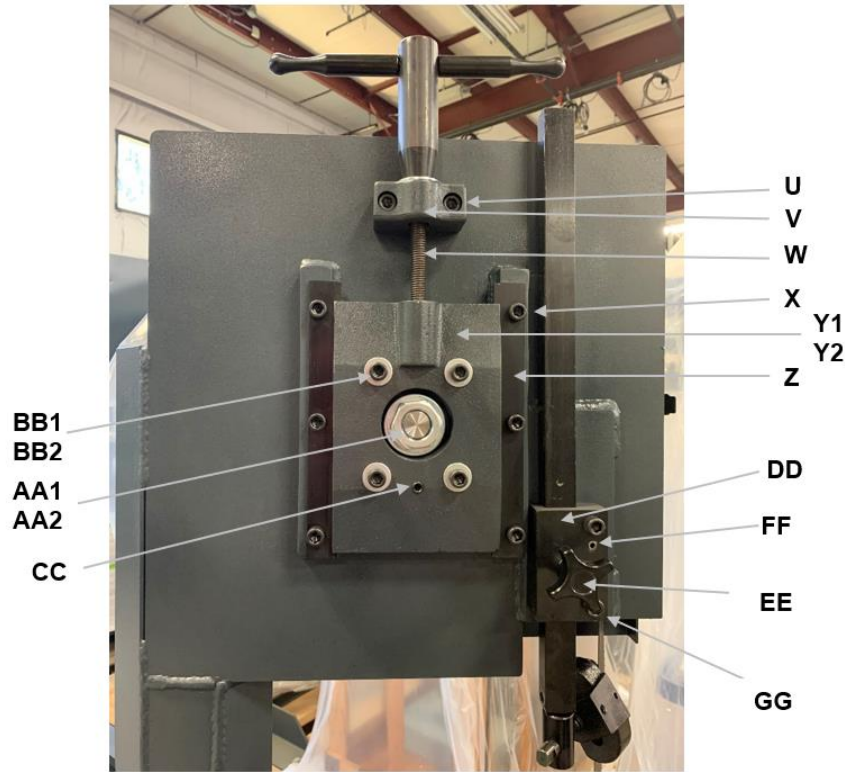

Item	Part Number	Description	Quantity
U	43450	Cap Screw	2
V	86827	Wheel Slide Tension Mounting block	1
W	10117-00	Tension Screw	1
X	43447	Cap Screw	6
Y1	86824	Wheel Slide – External piece	1
Y2	86825	Wheel Slide Adjustment – Internal piece	1
Z	86826	Rail Wheel Slide	2
AA1	43922	Nut	1
AA2	43638	Washer	1
BB1	43452	Soc Cap Screw 3/8-16 x 1-3/4	4
BB2	43632	Washer 5/16" flat	4
CC	43591	Set Screw 3/8-16 x 1	1
DD	86810	Guide Bar Holder	1
EE	300832	Knob Assembly 1-1/2"	1
FF	70287	Roll pin	2
GG	43451	Cap Screw	2

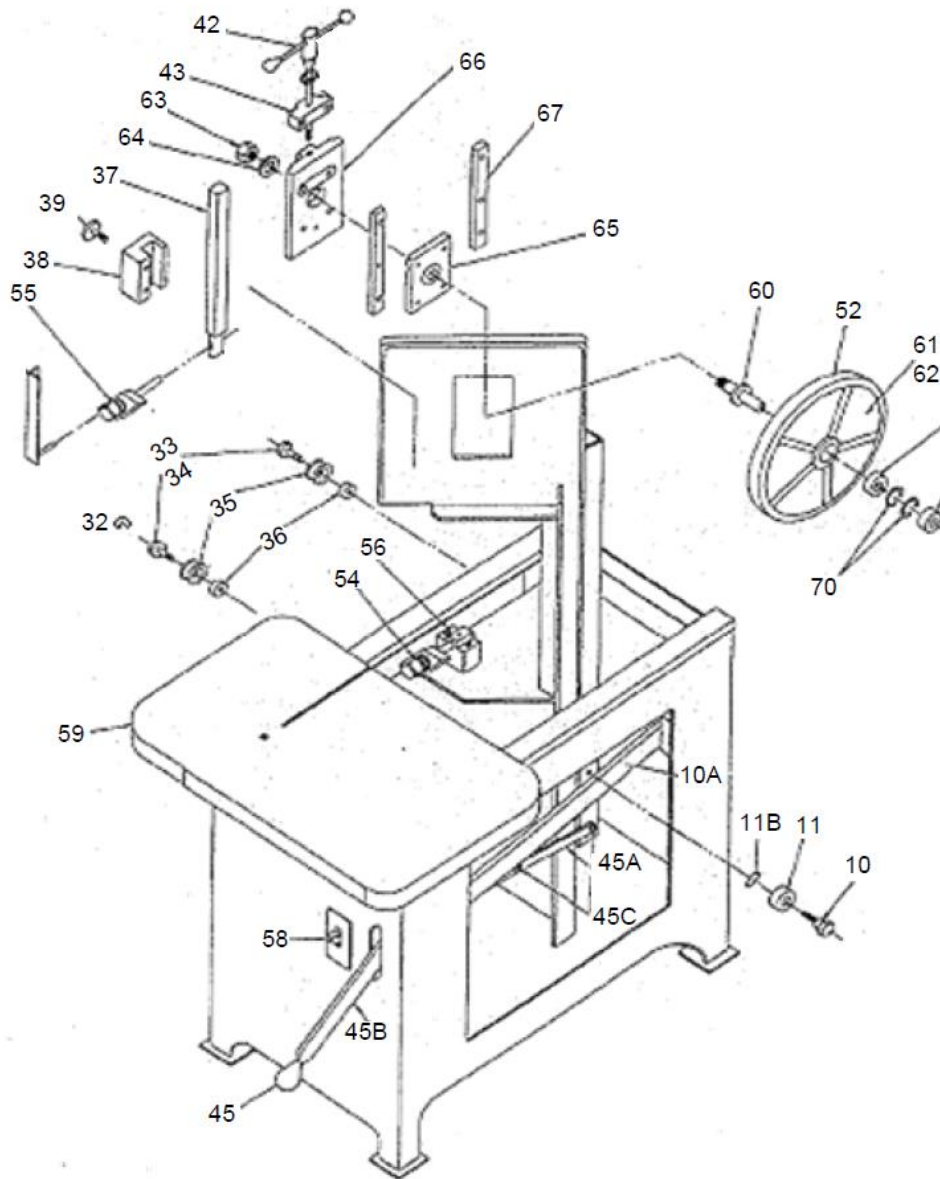

Item	Part Number	Description	Quantity
N/A	86806B	Contour Insert, Brass, Large (1/2")	1
N/A	86807B	Contour Insert, Brass, Small (1/4")	-
N/A	86792	Contour Guides (Casting)	-
N/A	86808	Contour Insert Holder	-
N/A	86806A	Carbide Inserts, Set of 2 (1/2")	-
N/A	86807A	Carbide Inserts, Set of 2 (1/4")	-
N/A	716723	Counterweight Assembly	1
N/A	86832	Feedweight	1
N/A	716709	Hydraulic Cylinder – OLD STYLE – Machines before 9/27/02. OBSOLETE – Must retrofit new style 716769	-
N/A	716769	Hydraulic Cylinder – NEW STYLE with retrofit kit. For machines after 9/27/02.	-
N/A	300505	Reservoir, Hydraulic Cylinder (1oz.) OLD STYLE	-
N/A	300510	Reservoir, Hydraulic Cylinder (2oz.) OLD STYLE	-
N/A	716754	Cylinder Rebuild Kit – OLD STYLE	-

N/A	300598	Shoulder Bolt, Hydraulic Cylinder	-
N/A	86836	Eccentric Roller Gravity Feed	2
10	86816	Stud Flat Track	1
10A	86852	Flat Track Rail	1
11	300471	Bearing Flat Track W204	1
11A	86839	Flat Track Roller Spacer	1
32	300477	E-Clip	1
33	86837	Stud Lever Weight	1
34	86819	Stud Grooved Roller	1
35	716706	Roller with Groove & Bearing	1
36	86838	Spacer Gravity Feed (3/8)	2
37	86815	Guide Support Bar – STD	-
37	86817	Guide Support Bar – SXC, XC (Current)	1
38	86810	Guide Bar Holder	1
39	300832	Guide Bar Lock Knob	2
40	86813	Swivel Guide Bar Support	1
42	716716	Tension Handle Assembly	1
43	86827	Pillow Block	1
44	86828	Tension Handle Body	1
44A	43634	Tension Handle Washer	1
44B	10117-00	Tension Screw	1
45	300450	Return Handle Knob	1
45A	86841	Return Handle Link	1
45B	86782	Return Handle	1
45C	43777	Return Handle Shoulder Bolt (1/2 x 1/2)	3
45D	24565	Return Handle Axle Bolt (1/2-13 x 3" SHCS)	-
45E	86839	Return Handle Spacer (1/4)	2
N/A	86798	Motor Mounting Axle	1
N/A	86800	Motor Mounting Block	2
52	300459	Band, Blade Wheel	2
53	10025-01	Roll Guide Bearing	4
54	87087	Roll Guide (1")	-
54	86809	Roll Guide (3/4")	4
54A	716717	Upper/Lower Roll Guide Assembly (Includes items 53, 54 (3/4"), 55, 56A, and screw)	1
55	86811	Guide Roller Holder	2
56	86805	Guide Roller Pillow Block	1
56A	86814	Eccentric Lower Guide	2
56B	86812	Pin, Lower Guide Rolls	-
57	86791	Frame Stop	1
58	300832	Stop Weight Knob	1
59	86796	Work Table	1
60	86803	Axle, Upper/Lower Wheel	2
62	86795	Blade Wheel	2
63	78650	Washer	2
64	300651	Nut	2
65	300693	Wheel Bearing (6205)	4
66	86824	Wheel Slide	1
67	86826	Rail, Wheel Slide	2
68	86825	Wheel Slide Adjustment	1



69	86804	Stud, Upper/Lower Wheel	2
70	300466	Retaining Ring, Blade Wheel	-
N/A	87065A	Wheel Guard	1
N/A	300685	Pulley Guard Assembly	1
N/A	300522	V-Belt	1
N/A	43632	Washer, Angle Plate	1
N/A	86835	Lever Link Weight	1

ORDER INFORMATION

- *Please contact factory for current prices*
- Parts are available for direct purchase from Dake or through a distributor. When placing a parts order, you will need to provide the part number, name of part, and model number. All parts shipped F.O.B. Factory in Grand Haven, MI.
- If a customer has any questions or concerns regarding a Dake product that was purchased, please email customer service at customerservice@dakecorp.com